

SERVICE & OPERATING MANUAL

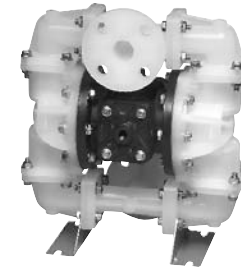

Model S10 Non-Metallic Design Level 1 Table of Contents

U.S. Patent #
400,210
5,996,627;
6,241,487



Engineering Data and Temperature Limitations.....	1
Explanation of Pump Nomenclature.....	2
Performance Curve.....	3
Dimensions: S10 Non-Metallic.....	4
Metric Dimensions: S10 Non-Metallic.....	5
Principle of Pump Operation.....	6
Installation and Start-up	6
Air Supply	6
Air Valve Lubrication	6
Air Line Moisture.....	6
Air Inlet and Priming	6
Between Uses	6
Installation Guide.....	7
Troubleshooting	8
Warranty	8
Important Safety Information	9
Material Codes	10
Composite Repair Parts Drawing	12
Overlay Option Drawing.....	12
Available Service and Conversion Kits	12
Composite Repair Parts List.....	13

Air Valve Assembly Drawing and Parts List	14
Air Valve Assembly Servicing	15
Air Valve with Stroke Indicator Drawing and Parts List	16
Air Valve with Stroke Indicator Servicing	17
Pilot Valve Servicing, Assembly Drawing and Parts List.....	18
Solenoid Shifted Valve Drawing and Parts List.....	19
Solenoid Shifted Air Distribution Valve Option	20
Intermediate Assembly Drawing.....	21
Intermediate Assembly Servicing	21
Modular Check Ball Valve Drawing.....	22
Modular Check Ball Valve Servicing.....	22
Diaphragm Service Drawing, Non-Overlay	23
Diaphragm Service Drawing with Overlay	23
Diaphragm Servicing, Overlay Diaphragm Servicing	24
Pumping Hazardous Liquids.....	25
Converting the Pump for Piping the Exhaust Air	25
Exhaust Conversion Drawing	25
Converted Exhaust Illustration.....	25
Pulse Output Kit Drawing, Option.....	26
Optional Muffler Configurations Drawing.....	27
CE Declaration of Conformity	28

**WARREN
RUPP®**

Quality System
ISO9001 Certified

Environmental
Management System
ISO14001 Certified

IDEX
FLUID & METERING

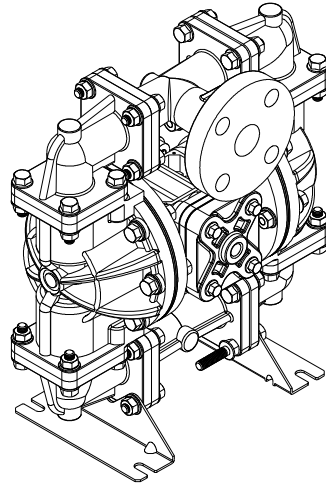

CE

U.S. Patent #
5,851,109; 5,996,627;
400,210 & 6,241,487
Other U.S. Patents
Applied for

SANDPIPER®
A WARREN RUPP PUMP BRAND

**S10 Non-Metallic
Design Level 1
Ball Valve
Air-Powered
Double-Diaphragm Pump**

ENGINEERING, PERFORMANCE
& CONSTRUCTION DATA

INTAKE/DISCHARGE PIPE SIZE 1" ANSI Flange	CAPACITY 0 to 23 US gallons per minute (0 to 87 liters per minute)	AIR VALVE No-lube, no-stall design	SOLIDS-HANDLING Up to .15 in. (4mm)	HEADS UP TO 100 psi or 231 ft. of water (7 bar or 70 meters)	DISPLACEMENT/STROKE .026 US gallon / .098 liter
---	---	---	---	---	---

⚠ CAUTION! Operating temperature limitations are as follows:

Materials	Operating Temperatures		
	Maximum*	Minimum*	Optimum**
Santoprene® Injection molded thermoplastic elastomer with no fabric layer. Long mechanical flex life. Excellent abrasion resistance.	275°F 135°C	-40°F -40°C	50° to 212°F 10°C to 100°C
PTFE Chemically inert, virtually impervious. Very few chemicals are known to react chemically with Teflon: molten alkali metals, turbulent liquid or gaseous fluorine and a few fluoro-chemicals such as chlorine trifluoride or oxygen difluoride which readily liberate free fluorine at elevated temperatures.	220°F 104°C	-35°F -37°C	50°F to 212°F 10°C to 100°C
PVDF	250°F 121°C	0°F -18°C	
Polypropylene	180°F 82°C	32°F 0°C	
Polyurethane	210°F 99°C	-40°F -40°C	-40°F to 210°F -40°C to 99°C
Nylon	180°F 82°C	32°F 0°C	
FKM (Fluorocarbon): Shows good resistance to a wide range of oils and solvents; especially all aliphatic, aromatic and halogenated hydrocarbons, acids, animal and vegetable oils. Hot water or hot aqueous solutions (over 70°F) will attack FKM.	350°F 177°C	-40°F -40°C	

For specific applications, always consult "Chemical Resistance Chart" Technical Bulletin

SANDPIPER® pumps are designed to be powered only by compressed air.

*Definite reduction in service life.

**Minimal reduction in service life at ends of range.

S10 Non-Metallic · Design Level 1 · Ball Valve

Type	Pump Brand	Pump Size	Check Valve Type	Design Level	Wetted Material	Diaphragm/Check Valve Options	Check Valve Seat	Non-Wetted Material Options	Porting Options	Pump Style	Pump Options	Kit Options	Shipping Weight lbs (kg)
S10B1P1PPAS000.	S	10	B	1	P	1	P	P	A	S	0	00.	19 (9)
S10B1P2PPAS000.	S	10	B	1	P	2	P	P	A	S	0	00.	19 (9)
S10B1K1KPAS000.	S	10	B	1	K	1	K	P	A	S	0	00.	23 (10)
S10B1K2KPAS000.	S	10	B	1	K	2	K	P	A	S	0	00.	23 (10)
S10B1N1NPAS000.	S	10	B	1	N	1	N	P	A	S	0	00.	20 (9)
S10B1N2NPAS000.	S	10	B	1	N	2	N	P	A	S	0	00.	20 (9)

Pump Brand

S= SandPIPER®

Pump Size

10= 1"

Check Valve Type

B= Ball

Design Level

1= Design Level 1

Wetted Material

K= PVDF

N= Nylon

P= Polypropylene

Diaphragm/Check Valve Materials

1= Santoprene/Santoprene

2= Virgin PTFE-Santoprene Backup/Virgin PTFE

7= Santoprene/Nitrile

8= Virgin PTFE-Santoprene Backup/FKM

Z= One-Piece Bonded/PTFE

Check Valve Seat

K= PVDF

N= Nylon

P= Polypropylene

Non-Wetted Material Options

P= Polypropylene

I= Polypropylene with PTFE Hardware

Porting Options

A= ANSI Flange

Pump Style

S= Standard

Pump Options

0= None

1= Sound Dampening Muffler

2= Mesh Muffler

6= Metal Muffler

Kit Options

00.= None

P0.= 10-30VDC Pulse Output Kit

P1.= Intrinsically-Safe 5-30VDC, 110/120VAC, 220/240VAC Pulse Output Kit

P2.= 110/120 or 220/240VAC Pulse Output Kit

E0.= Solenoid Kit w/24VDC Coil

E1.= Solenoid Kit 24VDC Explosion-Proof Coil

E2.= Solenoid Kit w/24VAC/12VDC Coil

E3.= Solenoid Kit w/12VDC Explosion-Proof Coil

E4.= Solenoid Kit w/110VAC Coil

E5.= Solenoid Kit w/110VAC 60 Hz Explosion-Proof Coil

E6.= Solenoid Kit w/220VAC Coil

E7.= Solenoid Kit w/220VAC 60 Hz Explosion-Proof Coil

E8.= Solenoid Kit w/110VAC 50 Hz Explosion-Proof Coil

E9.= Solenoid Kit w/230VAC 50 Hz Explosion-Proof Coil

SP= Stroke Indicator Pins

Performance Curve, S10 Non-Metallic, Design Level 1 Curve

MODEL S10 Non-Metallic Performance Curve

Performance based on the following: elastomer fitted pump, flooded suction, water at ambient conditions.
The use of other materials and varying hydraulic conditions may result in deviations in excess of 5%.

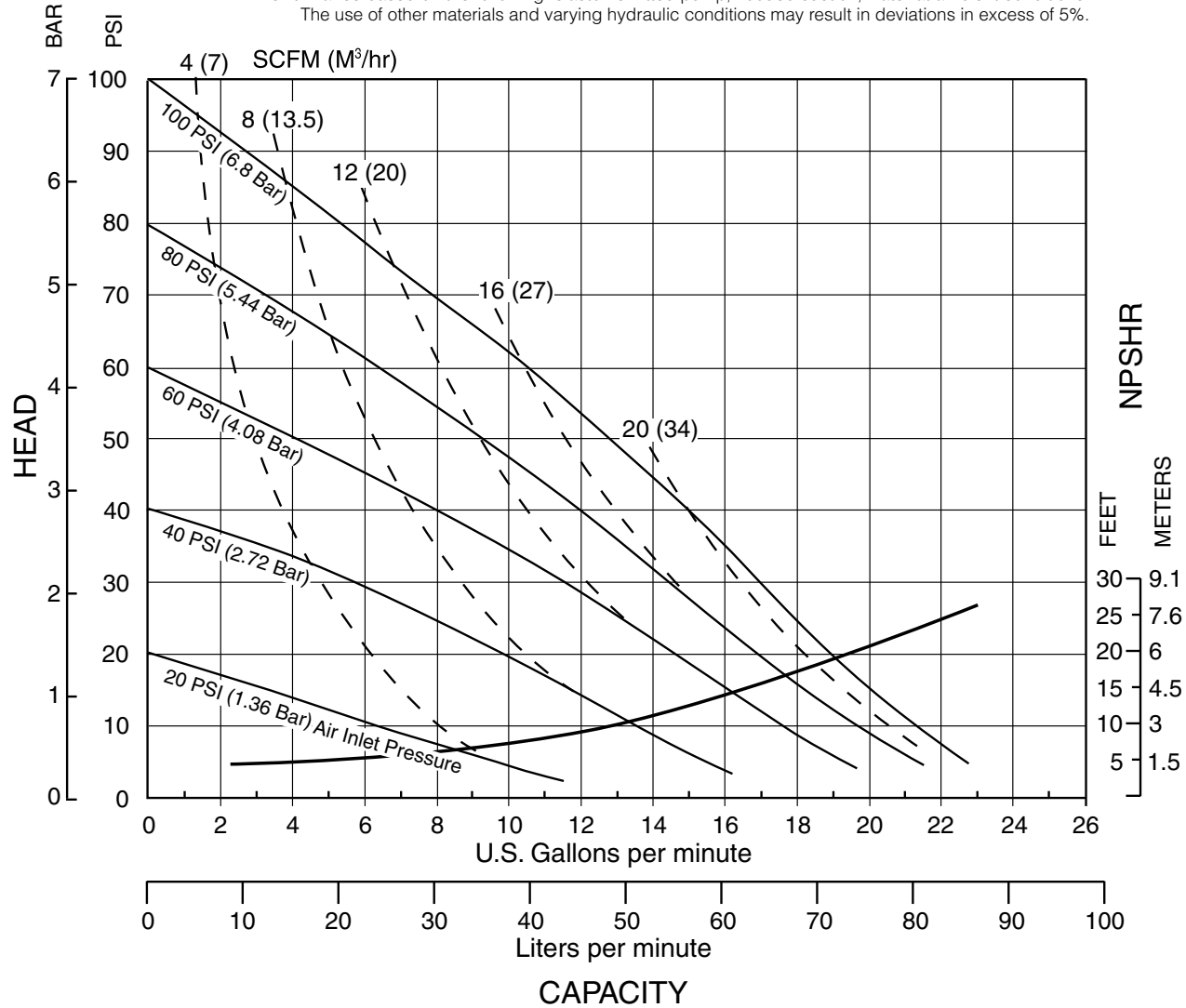

Dimensions: S10 Non-Metallic

Dimensions in Inches

Dimensional tolerance: $\pm 1/8"$

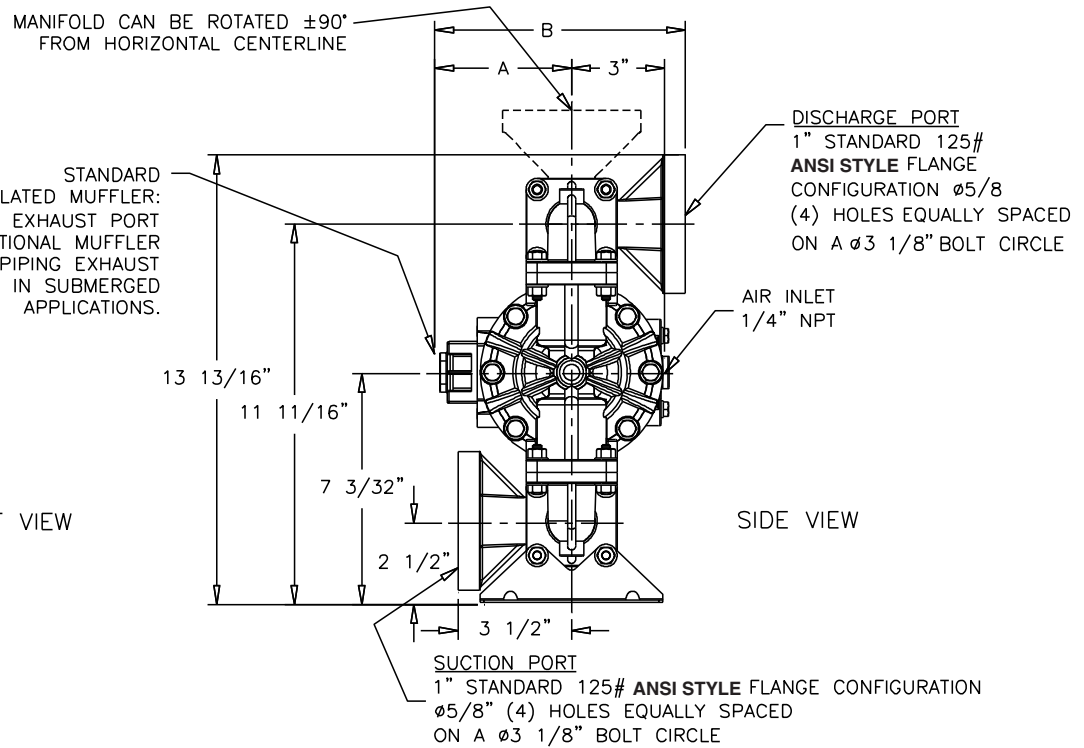
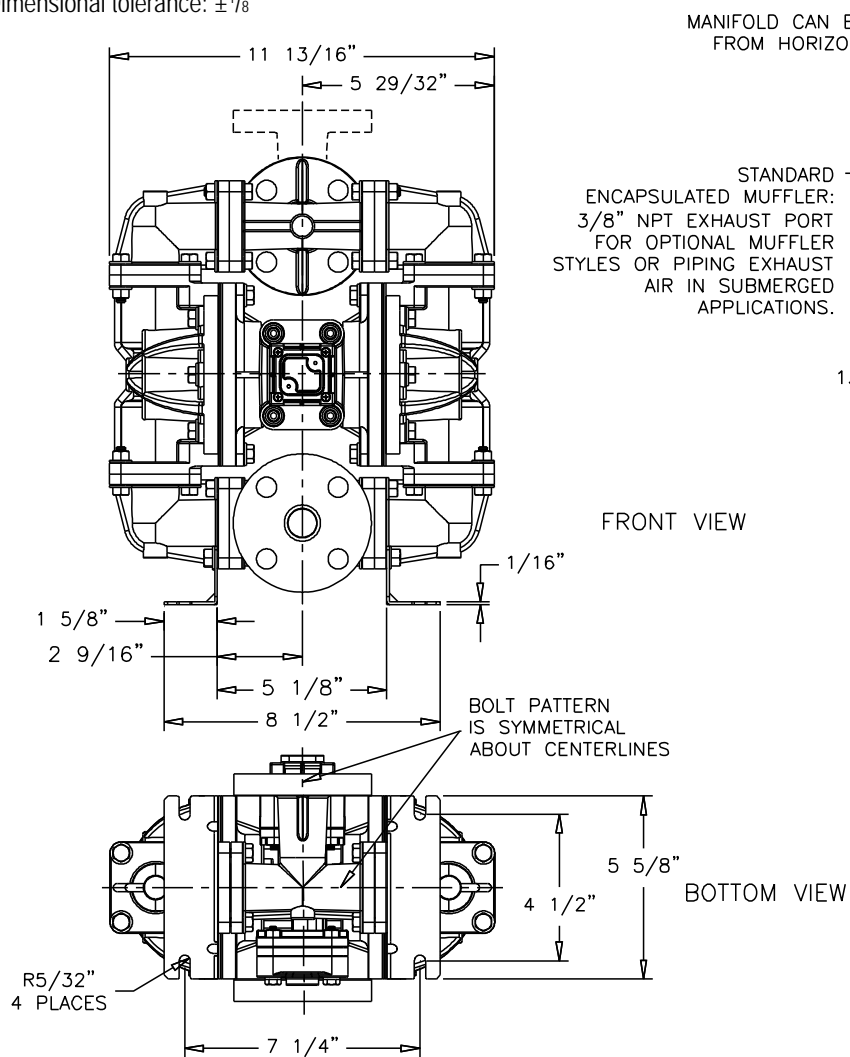

Dimension	A	B
Standard Pump	4 1/16"	7 9/16"
Pulse Output Kit	4 1/16"	9 5/16"
Mesh Muffler	5 3/4"	9 1/4"

Metric Dimensions: S10 Non-Metallic

Dimensions in Millimeters

Dimensional tolerance: $\pm 3\text{mm}$

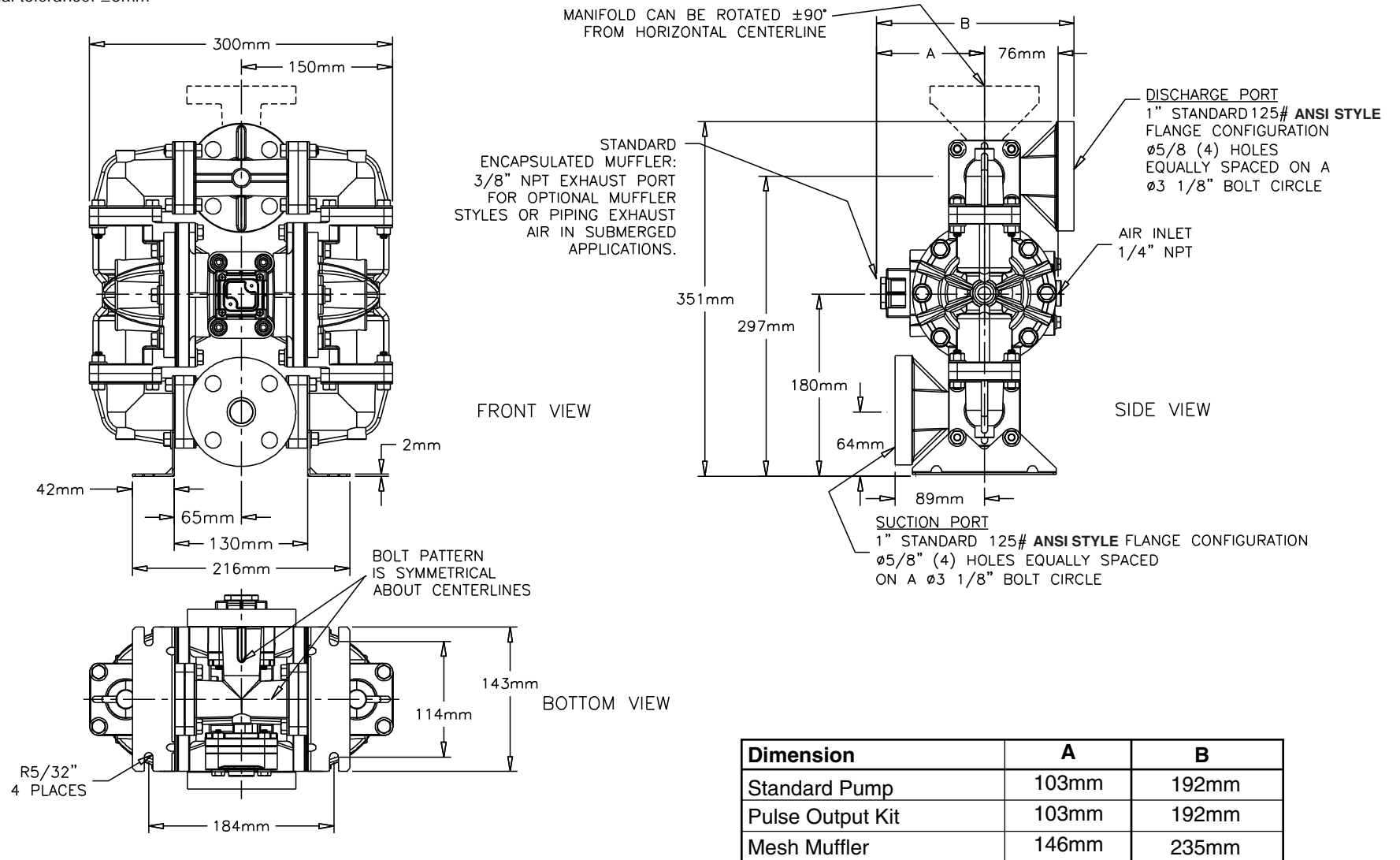

PRINCIPLE OF PUMP OPERATION

This ball type check valve pump is powered by compressed air and is a 1:1 ratio design. The inner side of one diaphragm chamber is alternately pressurized while simultaneously exhausting the other inner chamber. This causes the diaphragms, which are connected by a common rod secured by plates to the centers of the diaphragms, to move in a reciprocating action. (As one diaphragm performs the discharge stroke the other diaphragm is pulled to perform the suction stroke in the opposite chamber.) Air pressure is applied over the entire inner surface of the diaphragm while liquid is discharged from the opposite side of the diaphragm. The diaphragm operates in a balanced condition during the discharge stroke which allows the pump to be operated at discharge heads over 200 feet (61 meters) of water.

For maximum diaphragm life, keep the pump as close to the liquid being pumped as possible. Positive suction head in excess of 10 feet of liquid (3.048 meters) may require a back pressure regulating device to maximize diaphragm life.

Alternate pressurizing and exhausting of the diaphragm chamber is performed by an externally mounted, pilot operated, four way spool type air distribution valve. When the spool shifts to one end of the valve body, inlet pressure is applied to one diaphragm chamber and the other diaphragm chamber exhausts. When the spool shifts to the opposite end of the valve

body, the pressure to the chambers is reversed. The air distribution valve spool is moved by a internal pilot valve which alternately pressurizes one end of the air distribution valve spool while exhausting the other end. The pilot valve is shifted at each end of the diaphragm stroke when a actuator plunger is contacted by the diaphragm plate. This actuator plunger then pushes the end of the pilot valve spool into position to activate the air distribution valve.

The chambers are connected with manifolds with a suction and discharge check valve for each chamber, maintaining flow in one direction through the pump.

INSTALLATION AND START-UP

Locate the pump as close to the product being pumped as possible. Keep the suction line length and number of fittings to a minimum. Do not reduce the suction line diameter.

For installations of rigid piping, short sections of flexible hose should be installed between the pump and the piping. The flexible hose reduces vibration and strain to the pumping system. A surge suppressor is recommended to further reduce pulsation in flow.

AIR SUPPLY

Air supply pressure cannot exceed 100 psi (7 bar). Connect the pump air inlet to an air supply of sufficient capacity and pressure required for desired performance. When the air supply line is solid piping, use a short length of flexible hose not less than

1/2" (13mm) in diameter between the pump and the piping to reduce strain to the piping. The weight of the air supply line, regulators and filters must be supported by some means other than the air inlet cap. Failure to provide support for the piping may result in damage to the pump. A pressure regulating valve should be installed to insure air supply pressure does not exceed recommended limits.

AIR VALVE LUBRICATION

The air distribution valve and the pilot valve are designed to operate WITHOUT lubrication. This is the preferred mode of operation. There may be instances of personal preference or poor quality air supplies when lubrication of the compressed air supply is required. The pump air system will operate with properly lubricated compressed air supply. Proper lubrication requires the use of an air line lubricator (available from Warren Rupp) set to deliver one drop of SAE 10 non-detergent oil for every 20 SCFM (9.4 liters/sec.) of air the pump consumes at the point of operation. Consult the pump's published Performance Curve to determine this.

AIR LINE MOISTURE

Water in the compressed air supply can create problems such as icing or freezing of the exhaust air, causing the pump to cycle erratically or stop operating. Water in the air supply can be reduced by using a point-of-use air dryer to supplement the user's air drying equipment. This device removes water from the compressed air supply

and alleviates the icing or freezing problems.

AIR INLET AND PRIMING

To start the pump, open the air valve approximately 1/2" to 3/4" turn. After the pump primes, the air valve can be opened to increase air flow as desired. If opening the valve increases cycling rate, but does not increase the rate of flow, cavitation has occurred. The valve should be closed slightly to obtain the most efficient air flow to pump flow ratio.

BETWEEN USES

When the pump is used for materials that tend to settle out or solidify when not in motion, the pump should be flushed after each use to prevent damage. (Product remaining in the pump between uses could dry out or settle out. This could cause problems with the diaphragms and check valves at restart.) In freezing temperatures the pump must be completely drained between uses in all cases.

INSTALLATION GUIDE Top Discharge Ball Valve Unit

Available from
Warren Rupp

- ① DA10 Surge Dampener
- ② 020-049-000 Filter/Regulator
- ③ Air Dryer

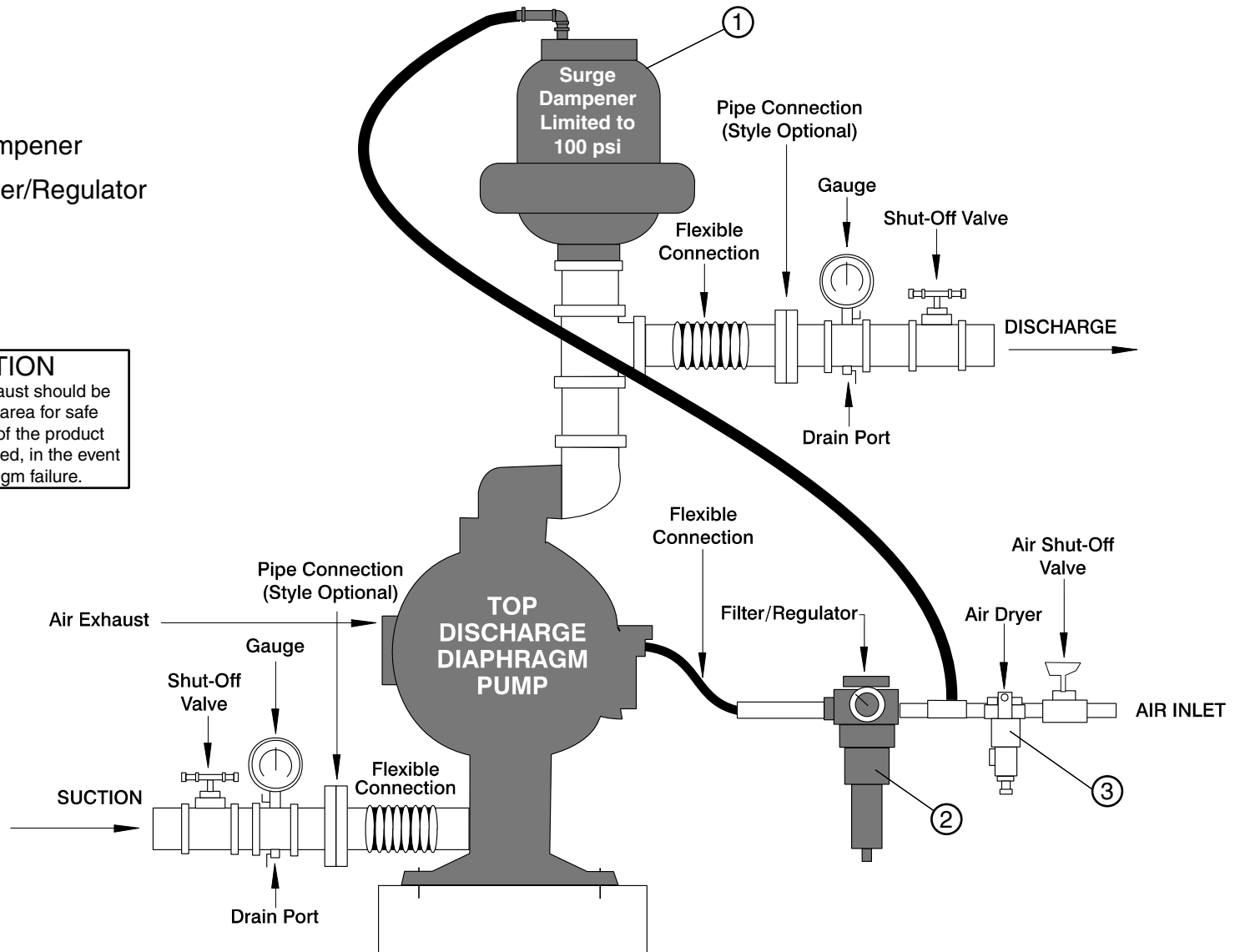
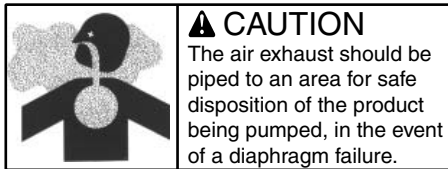

TROUBLESHOOTING

Possible Symptoms:

- Pump will not cycle.
- Pump cycles, but produces no flow.
- Pump cycles, but flow rate is unsatisfactory.
- Pump cycle seems unbalanced.
- Pump cycle seems to produce excessive vibration.

What to Check: Excessive suction lift in system.

Corrective Action: For lifts exceeding 20 feet (6 meters), filling the pumping chambers with liquid will prime the pump in most cases.

What to Check: Excessive flooded suction in system.

Corrective Action: For flooded conditions exceeding 10 feet (3 meters) of liquid, install a back pressure device.

What to Check: System head exceeds air supply pressure.

Corrective Action: Increase the inlet air pressure to the pump. Most diaphragm pumps are designed for 1:1 pressure ratio at zero flow.

What to Check: Air supply pressure or volume exceeds system head.

Corrective Action: Decrease inlet air pressure and volume to the pump as calculated on the published PERFORMANCE CURVE. Pump is cavitating the fluid by fast cycling.

What to Check: Undersized suction line.

Corrective Action: Meet or exceed pump connection recommendations shown on the DIMENSIONAL DRAWING.

What to Check: Restricted or undersized air line.

Corrective Action: Install a larger air line and connection. Refer to air inlet recommendations shown in your pump's SERVICE MANUAL.

What to Check: Check ESADS, the Externally Serviceable Air Distribution System of the pump.

Corrective Action: Disassemble and inspect the main air distribution valve, pilot valve and pilot valve actuators. Refer to the parts drawing and air valve section of the SERVICE MANUAL. Check for clogged discharge or closed valve before reassembly.

What to Check: Rigid pipe connections to pump.

Corrective Action: Install flexible connectors and a surge suppressor.

What to Check: Blocked air exhaust muffler.

Corrective Action: Remove muffler screen, clean or de-ice and reinstall. Refer to the Air Exhaust section of your pump SERVICE MANUAL.

What to Check: Pumped fluid in air exhaust muffler.

Corrective Action: Disassemble pump chambers. Inspect for diaphragm rupture or loose diaphragm plate assembly. Refer to the Diaphragm Replacement section of your pump SERVICE MANUAL.

What to Check: Suction side air leakage or air in product.

Corrective Action: Visually inspect all suction side gaskets and pipe connections.

What to Check: Obstructed check valve.

Corrective Action: Disassemble the wet end of the pump and manually dislodge obstruction in the check valve pocket. Refer to the Check Valve section of the pump SERVICE MANUAL for disassembly instructions.

What to Check: Worn or misaligned check valve or check valve seat.

Corrective Action: Inspect check valves and seats for wear and proper seating. Replace if necessary. Refer to Check Valve section of the pump SERVICE MANUAL for disassembly instructions.

What to Check: Blocked suction line.

Corrective Action: Remove or flush obstruction. Check and clear all suction screens and strainers.

What to Check: Blocked discharge line.

Corrective Action: Check for obstruction or closed discharge line valves.

What to Check: Blocked pumping chamber.

Corrective Action: Disassemble and inspect the wetted chambers of the pump. Remove or flush any obstructions. Refer to the pump SERVICE MANUAL for disassembly instructions.

What to Check: Entrained air or vapor lock in one or both pumping chambers.

Corrective Action: Purge chambers through tapped chamber vent plugs. PURGING THE CHAMBERS OF AIR CAN BE DANGEROUS! Contact the Warren Rupp Technical Service Team before performing this procedure. A model with top-ported discharge will reduce or eliminate problems with entrained air.

If your pump continues to perform below your expectations, contact your local Warren Rupp Distributor or factory Technical Service Team for a service evaluation.

WARRANTY

Refer to the enclosed Warren Rupp Warranty Certificate.

Recycling

Many components of SANDPIPER® Metallic AODD pumps are made of recyclable materials (see chart on page 9 for material specifications). We encourage pump users to recycle worn out parts and pumps whenever possible, after any hazardous pumped fluids are thoroughly flushed.

Important Safety Information



IMPORTANT

Read these safety warnings and instructions in this manual completely, before installation and start-up of the pump. It is the responsibility of the purchaser to retain this manual for reference. Failure to comply with the recommendations stated in this manual will damage the pump, and void factory warranty.



CAUTION

Before pump operation, inspect all gasketed fasteners for looseness caused by gasket creep. Retorque loose fasteners to prevent leakage. Follow recommended torques stated in this manual.



WARNING

Before maintenance or repair, shut off the compressed air line, bleed the pressure, and disconnect the air line from the pump. The discharge line may be pressurized and must be bled of its pressure.



WARNING

When used for toxic or aggressive fluids, the pump should always be flushed clean prior to disassembly.



WARNING

Take action to prevent static sparking. Fire or explosion can result, especially when handling flammable liquids. The pump, piping, valves, containers or other miscellaneous equipment must be grounded.



WARNING

This pump is pressurized internally with air pressure during operation. Always make certain that all bolting is in good condition and that all of the correct bolting is reinstalled during assembly.



WARNING

In the event of diaphragm rupture, pumped material may enter the air end of the pump, and be discharged into the atmosphere. If pumping a product which is hazardous or toxic, the air exhaust must be piped to an appropriate area for safe disposition.



WARNING

Before doing any maintenance on the pump, be certain all pressure is completely vented from the pump, suction, discharge, piping, and all other openings and connections. Be certain the air supply is locked out or made non-operational, so that it cannot be started while work is being done on the pump. Be certain that approved eye protection and protective clothing are worn all times in the vicinity of the pump. Failure to follow these recommendations may result in serious injury or death.

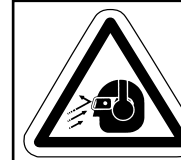

WARNING

Airborne particles and loud noise hazards. Wear ear and eye protection.



Pump complies with EN809 Pumping Directive, Directive 98/37/EC Safety of Machinery. For reference to the declarations of conformity visit: www.warrenrupp.com.

Material Codes

The Last 3 Digits of Part Number

000	Assembly, sub-assembly; and some purchased items	180	Copper Alloy	378	High Density Polypropylene	604	PTFE
010	Cast Iron	305	Carbon Steel, Black Epoxy Coated	379	Conductive Nitrile	606	PTFE
012	Powered Metal	306	Carbon Steel, Black PTFE Coated	405	Cellulose Fibre	607	Envelon
015	Ductile Iron	307	Aluminum, Black Epoxy Coated	408	Cork and Neoprene	608	Conductive PTFE
020	Ferritic Malleable Iron	308	Stainless Steel, Black PTFE Coated	425	Compressed Fibre	610	PTFE Integral Silicon
025	Music Wire	309	Aluminum, Black PTFE Coated	426	Blue Gard	611	PTFE Integral FKM
080	Carbon Steel, AISI B-1112	310	PVDF Coated	440	Vegetable Fibre	632	Neoprene/Hytrel
100	Alloy 20	330	Zinc Plated Steel	465	Fibre	633	FKM (Fluorocarbon)/PTFE
110	Alloy Type 316 Stainless Steel	331	Chrome Plated Steel	500	Delrin 500	634	EPDM/PTFE
111	Alloy Type 316 Stainless Steel (Electro Polished)	332	Aluminum, Electroless Nickel Plated	501	Delrin 570	635	Neoprene/PTFE
112	Alloy C	333	Carbon Steel, Electroless Nickel Plated	502	Conductive Acetal, ESD-800	637	PTFE, FKM (Fluorocarbon)/PTFE
113	Alloy Type 316 Stainless Steel (Hand Polished)	335	Galvanized Steel	503	Conductive Acetal, Glass-Filled	638	PTFE, Hytrel/PTFE
114	303 Stainless Steel	336	Zinc Plated Yellow Brass	505	Acrylic Resin Plastic	639	Nitrile/TFE
115	302/304 Stainless Steel	337	Silver Plated Steel	506	Delrin 150	643	Santoprene/EPDM
117	440-C Stainless Steel (Martensitic)	340	Nickel Plated	520	Injection Molded PVDF Natural color	644	Santoprene/PTFE
120	416 Stainless Steel (Wrought Martensitic)	342	Filled Nylon	521	Conductive PVDF	650	Bonded Santoprene and PTFE
123	410 Stainless Steel (Wrought Martensitic)	353	Geolast; Color: Black	540	Nylon	654	Santoprene Diaphragm, PTFE Overlay Balls and seals
148	Hardcoat Anodized Aluminum	354	Injection Molded #203-40 Santoprene- Duro 40D +/-5; Color: RED	541	Nylon	656	Santoprene Diaphragm and Check Balls/EPDM Seats
149	2024-T4 Aluminum	355	Thermal Plastic	542	Nylon	661	EPDM/Santoprene
150	6061-T6 Aluminum	356	Hytrel	544	Nylon Injection Molded		
151	6063-T6 Aluminum	357	Injection Molded Polyurethane	550	Polyethylene		
152	2024-T4 Aluminum (2023-T351)	358	Urethane Rubber (Some Applications) (Compression Mold)	551	Glass Filled Polypropylene		
154	Almag 35 Aluminum	359	Urethane Rubber	552	Unfilled Polypropylene		
155	356-T6 Aluminum	360	Nitrile Rubber. Color coded: RED	553	Unfilled Polypropylene		
156	356-T6 Aluminum	361	FDA Accepted Nitrile	555	Polyvinyl Chloride		
157	Die Cast Aluminum Alloy #380	363	FKM (Fluorocarbon). Color coded: YELLOW	556	Black Vinyl		
158	Aluminum Alloy SR-319	364	E.P.D.M. Rubber. Color coded: BLUE	557	Conductive Polypropylene		
159	Anodized Aluminum	365	Neoprene Rubber. Color coded: GREEN	558	Conductive HDPE		
162	Brass, Yellow, Screw Machine Stock	366	Food Grade Nitrile	559	Glass-Filled Conductive Polypropylene		
165	Cast Bronze, 85-5-5-5	368	Food Grade EPDM	570	Rulon II		
166	Bronze, SAE 660	370	Butyl Rubber. Color coded: BROWN	580	Ryton		
170	Bronze, Bearing Type, Oil Impregnated	371	Philthane (Tuftane)	590	Valox		
175	Die Cast Zinc	374	Carboxylated Nitrile	591	Nylatron G-S		
		375	Fluorinated Nitrile	592	Nylatron NSB		
				600	PTFE (virgin material) Tetrafluorocarbon (TFE)		
				601	PTFE (Bronze and moly filled)		
				602	Filled PTFE		
				603	Blue Gylon		

Delrin and Hytrel are registered tradenames of E.I. DuPont.

Gylon is a registered tradename of Garlock, Inc.

Nylatron is a registered tradename of Polymer Corp.

Santoprene is a registered tradename of Monsanto Corp.

Rulon II is a registered tradename of Dixon Industries Corp.

Ryton is a registered tradename of Phillips Chemical Co.

Valox is a registered tradename of General Electric Co.

Warren Rupp, SANDPIPER, Portapump, Tranquilizers and SludgeMaster are registered tradenames of Warren Rupp, Inc.

Composite Repair Parts Drawing

AVAILABLE SERVICE AND CONVERSION KITS

476-219-000 AIR END KIT

Seals, O-rings, Gaskets, Bumpers, Retaining Rings, Air Valve Assembly and Pilot Valve Assembly.

476-220-000 AIR END KIT for pumps

equipped with Stroke Indicator (same components as above, except Valve Assembly with pins replaces Standard Air Valve).

476-166-354 WETTED END KIT

Santoprene Diaphragms, Nitrile Spacer Gaskets, Santoprene Check Balls and TFE Seals.

476-166-650 WETTED END KIT

One-Piece Bond Diaphragm, PTFE Check Balls and PTFE Seals.

476-166-654 WETTED END KIT

Santoprene Diaphragms, TFE Overlay Diaphragm, TFE Check Balls and TFE Seals.

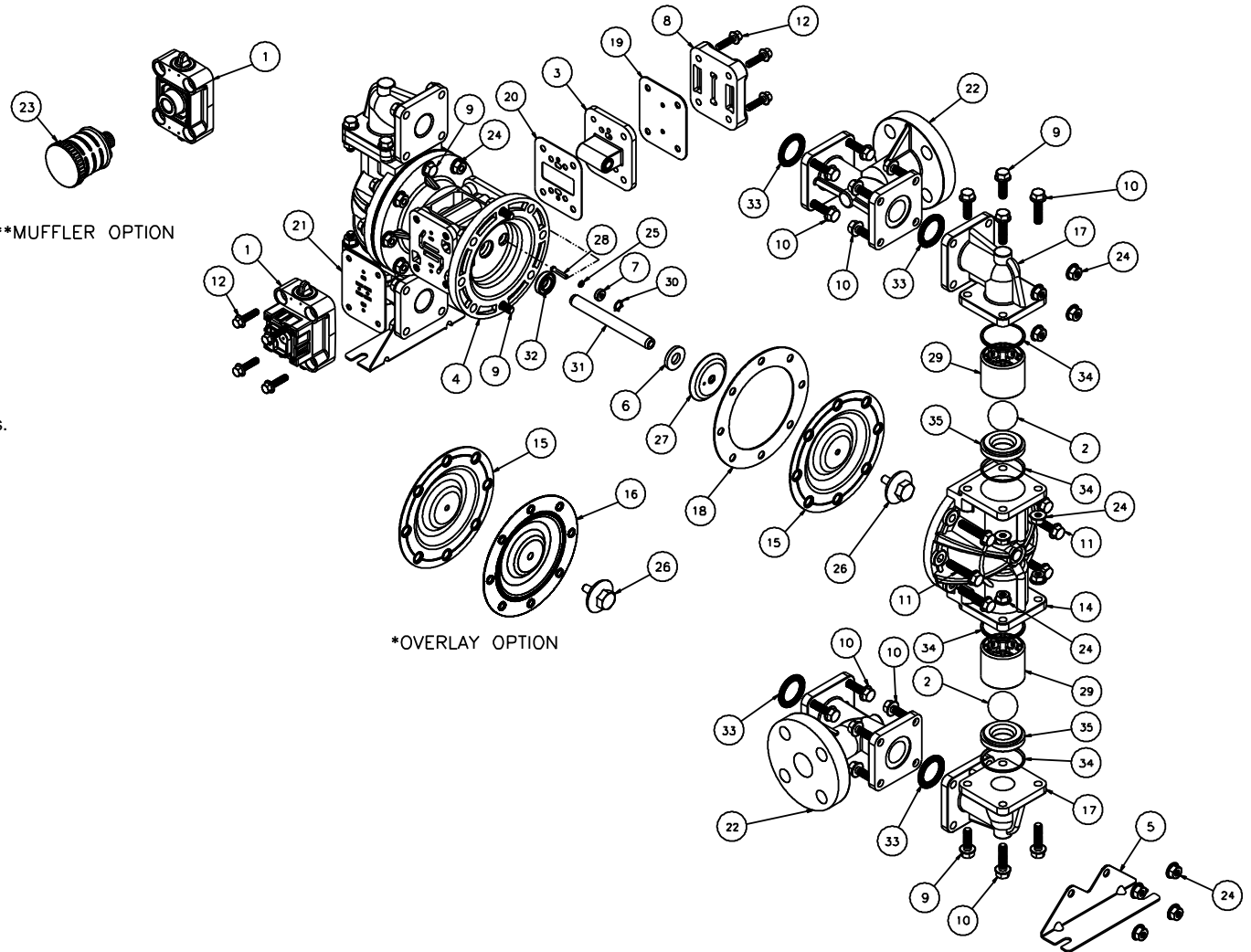

Composite Repair Parts List

NOTE: See Pages 14 and 16 For Full Explanation of Air Valve Options.

ITEM	PART NUMBER	DESCRIPTION	QTY	ITEM	PART NUMBER	DESCRIPTION	QTY
1	031-166-000	Air Valve Assembly (Integral Muffler)	1	17	312-107-520	Elbow	4
	031-166-002	Air Valve Assembly (with PTFE Coated Hardware)	1		312-107-542	Elbow	4
	031-167-000	Air Valve Assembly (with stroke Indicator Pins)	1		312-107-552	Elbow	4
	031-167-002	Air Valve Assembly (with Stroke Indicator Pins and PTFE Coated Hardware)	1	18	360-099-360	Gasket, Spacer	2
	031-168-000	Air Valve Assembly (Optional Mufflers)	1	19	360-100-360	Gasket, Air Inlet	1
	031-168-000	Air Valve Assembly (Stroke Indicator & Optional Mufflers)	1	20	360-101-379	Gasket, Pilot Valve	1
	031-176-000	Air Valve (High Temperature)	1	21	360-102-360	Gasket, Air Valve	1
	031-177-000	Air Valve (High Temperature With Mufflers)	1	22	518-140-520	Manifold (ANSI)	2
2	050-028-354	Ball, Check Valve	4		518-140-542	Manifold (ANSI)	2
	050-028-600	Ball, Check Valve	4		518-140-552	Manifold (ANSI)	2
3	095-091-000	Pilot Valve Assembly	1	23	530-023-600	Muffler	1
	095-091-558	Pilot Valve Assembly (Conductive Acetal)	1		530-024-000	Muffler	1
4	114-023-551	Bracket, Intermediate	1	24	544-005-115	Nut, Flanged 5/16-18	36
5	115-142-115	Bracket, Mounting	2		544-005-308	Nut, Flanged 5/16-18	36
6	132-034-360	Bumper, Diaphragm	2	25	560-001-360	O-ring	2
7	135-036-506	Bushing, Plunger	2	26	612-091-520	Plate, Outer Diaphragm	2
8	165-110-551	Cap, Air Inlet	1		612-091-542	Plate, Outer Diaphragm	2
9	171-062-115	Capscrew, Flanged 5/16-18 x 1.00	8		612-091-552	Plate, Outer Diaphragm	2
	171-062-308	Capscrew, Flanged 5/16-18 x 1.00	8	27	612-177-150	Plate, Inner Diaphragm	2
	171-075-115	Capscrew, Flanged 5/16-18x 1.00	4		612-221-330	Plate, Inner Diaphragm (use with One-Piece Bonded Diaphragm only)	2
10	171-063-115	Capscrew, Flanged 5/16-18 x 1.25	24	28	620-019-115	Plunger, Actuator	2
	171-063-308	Capscrew, Flanged 5/16-18 x 1.25	24	29	670-050-520	Retainer, Ball	4
11	171-064-115	Capscrew, Flanged 5/16-18 x 1.50	12		670-050-542	Retainer, Ball	4
	171-064-308	Capscrew, Flanged 5/16-18 x 1.50	12		670-050-552	Retainer, Ball	4
12	171-066-115	Capscrew, Flanged 1/4-20 x 1.25	8	30	675-042-115	Ring, Retaining	2
	171-066-308	Capscrew, Flanged 1/4-20 x 1.25	8	31	685-056-120	Rod, Diaphragm	1
14	196-162-520	Chamber, Outer	2	32	720-012-375	Seal, Diaphragm Rod	2
	196-162-542	Chamber, Outer	2	33	720-046-600	Seal, Manifold	4
	196-162-552	Chamber, Outer	2	34	720-051-600	Seal, Check Valve Retainer	8
15	286-095-354	Diaphragm	2	35	722-081-520	Seat, Check Valve	4
	286-116-000	Diaphragm, One-Piece Bonded	2		722-081-542	Seat, Check Valve	4
16	286-096-600	Diaphragm, Overlay	2		722-081-552	Seat, Check Valve	4
				NOT SHOWN:			
					535-069-000	Nameplate	

Air Distribution Valve Assembly Drawing

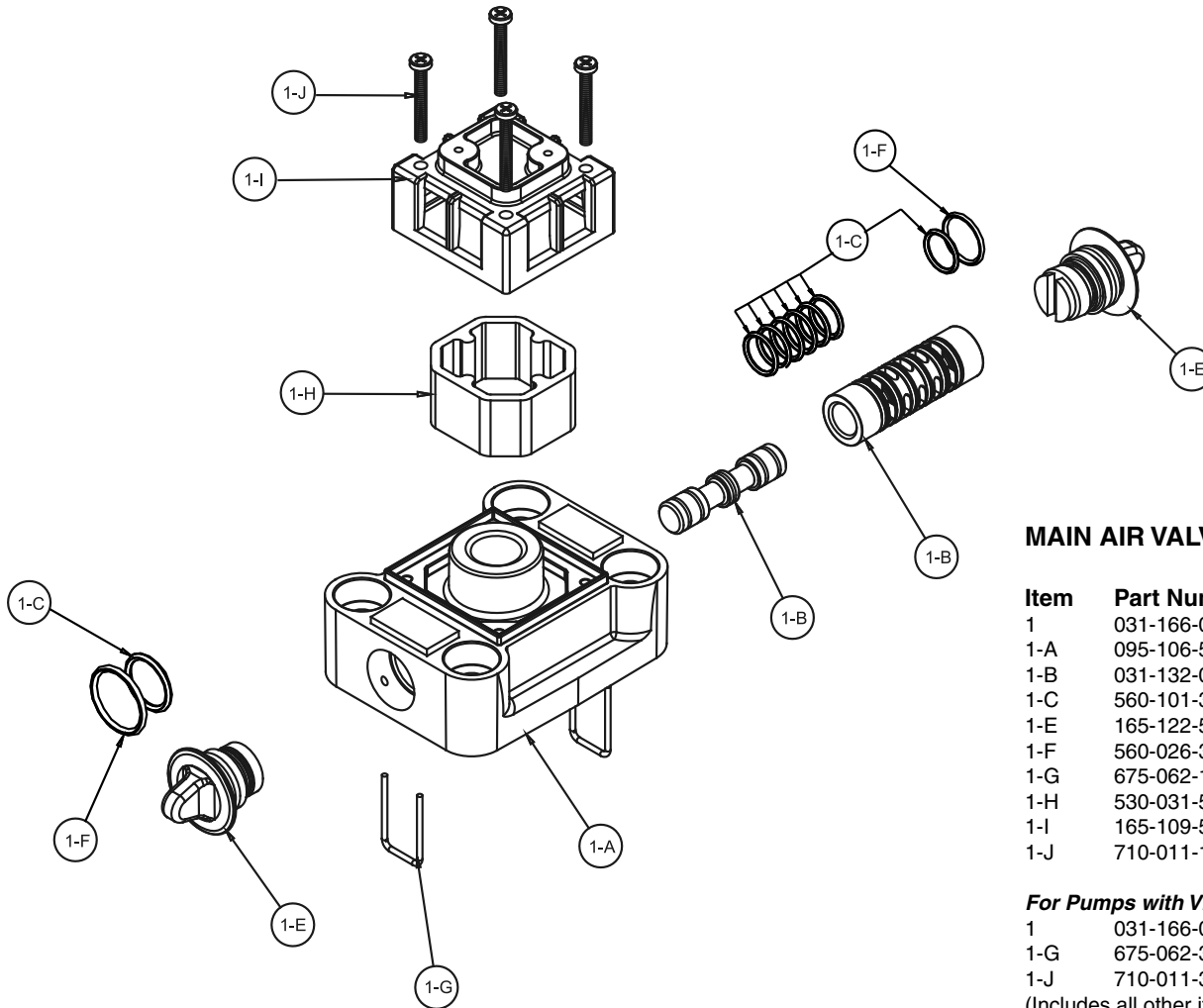

MAIN AIR VALVE ASSEMBLY PARTS LIST

Item	Part Number	Description	Qty
1	031-166-000	Air Valve Assembly	1
1-A	095-106-551	Body, Air Valve	1
1-B	031-132-000	Sleeve and Spool Set	1
1-C	560-101-360	O-Ring	8
1-E	165-122-551	End Cap	2
1-F	560-026-360	O-Ring	2
1-G	675-062-115	End Cap Retainer	2
1-H	530-031-550	Muffler	1
1-I	165-109-551	Muffler Cap	1
1-J	710-011-115	Self-Tapping Screw	4

For Pumps with Virgin PTFE coated hardware:

1	031-166-002	Air Valve Assembly	1
1-G	675-062-308	End Cap Retainer	2
1-J	710-011-308	Self Tapping Screw	4

(Includes all other items used on 031-166-000 above)

For Pumps with alternate Mesh or Sound Dampening Mufflers or Piped Exhaust:

1	031-168-000	Air Valve Assembly	1
---	-------------	--------------------	---

(Includes all items used on 031-166-000 above minus 1-H, 1-I and 1-J)

AIR DISTRIBUTION VALVE SERVICING

To service the air valve first shut off the compressed air, bleed pressure from the pump, and disconnect the air supply line from the pump.

STEP #1: See COMPOSITE REPAIR PARTS DRAWING.

Using a 3/8" wrench or socket, remove the four hex flanged capscrews (item 12). Remove the air valve assembly from the pump.

STEP #2: Disassembly of the air valve.

To access the internal air valve components first remove the two end cap retainers (item 1-G) by inserting a small flat screwdriver into the two slotted grooves on the valve body and gently lifting the retainers out.

Next remove the two end caps (item 1-E) by grasping the pull tab with finger and thumb or pliers and tugging. Inspect the two o-rings (items 1-C and 1-F) on each end cap for wear or cuts. Replace the o-rings if necessary.

Remove the spool (part of item 1-B) from the sleeve. Be careful not to scratch or damage the outer diameter of the spool. Wipe spool with a soft clean cloth and inspect for scratches or abrasive wear.

Inspect the inner diameter of the sleeve (part of item 1-B) for dirt, scratches, or other contaminants. Remove the sleeve if needed and replace with a new sleeve and spool set (item 1-B). **Note:** The sleeve and spool set is match-ground to a specified clearance. Sleeves and spools cannot be interchanged.

STEP #3: Reassembly of the air distribution valve.

Install one end cap with o-rings (items 1-E, 1-C, and 1-F) into one end of the air valve body (item 1-A). Insert one end cap retainer (item 1-G) into the two smaller holes, align with groove in the end cap, and push until the closed end of the retainer is below the flat surface of the valve body.

Remove the new sleeve and spool set (item 1-B) from the plastic bag. Carefully remove the spool from the sleeve. Install the six o-rings (item 1-C) into the six grooves on the sleeve. Apply a light coating of grease to the o-rings before installing the sleeve into the valve body. Align the slots in the sleeve with the slots in the valve body. Insert the spool into the sleeve. Be careful not to scratch or damage the spool during installation. Push the spool in until the pin touches the end cap on the opposite end.

Install the remaining end cap with o-rings and retaining ring.

Fasten the air valve assembly (item 1) and gasket (item 23) to the pump, using the four hex flanged capscrews (item 12).

Connect the compressed air line to the pump. The pump is now ready for operation.



! IMPORTANT

Read these instructions completely, before installation and start-up. It is the responsibility of the purchaser to retain this manual for reference.

Failure to comply with the recommendations stated in this manual will damage the pump, and void factory warranty.

Air Valve with Stroke Indicator Assembly Drawing, Parts List

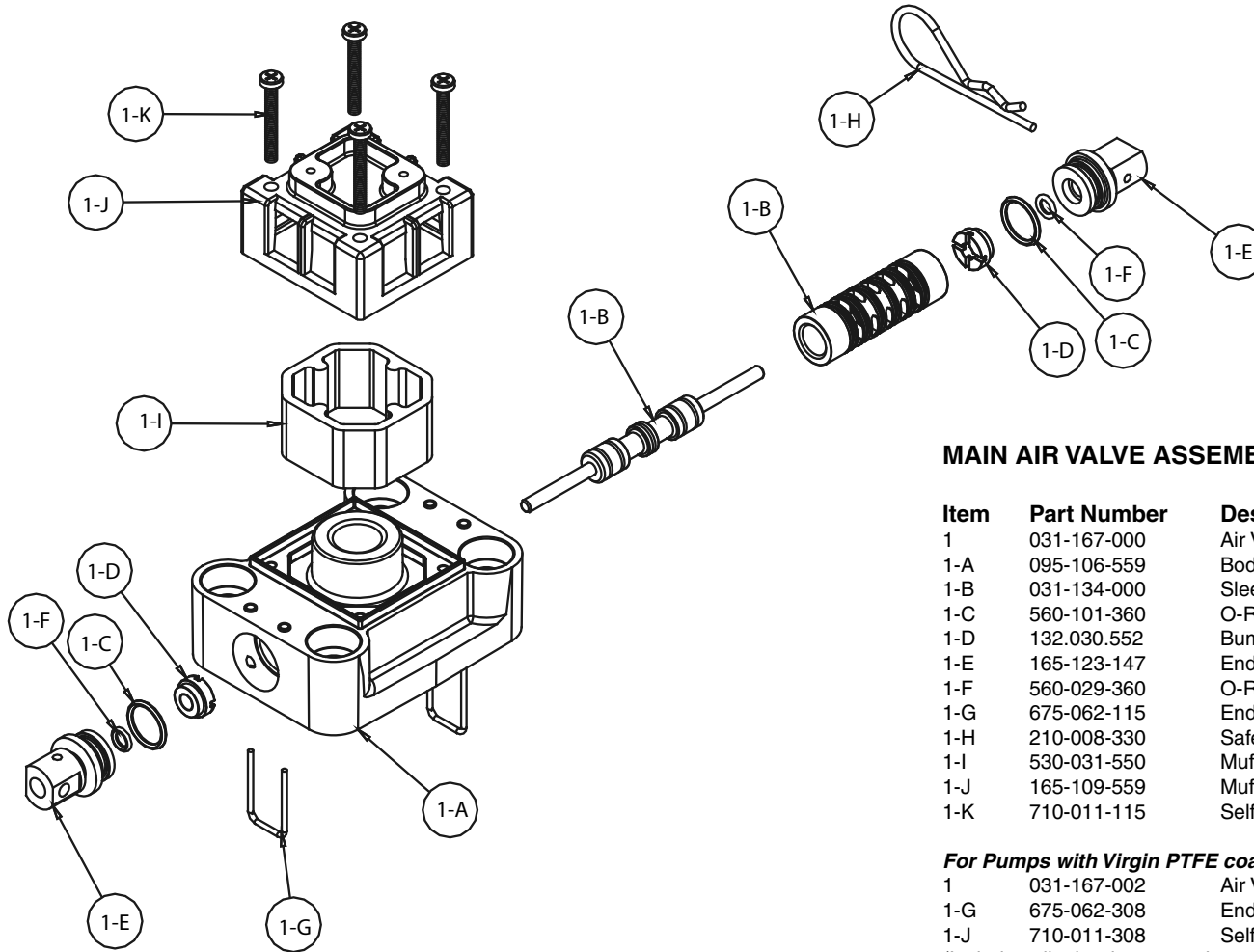

MAIN AIR VALVE ASSEMBLY PARTS LIST

Item	Part Number	Description	Qty
1	031-167-000	Air Valve Assembly	1
1-A	095-106-559	Body, Air Valve	1
1-B	031-134-000	Sleeve and Spool Set	1
1-C	560-101-360	O-Ring	8
1-D	132.030.552	Bumper	2
1-E	165-123-147	End Cap	2
1-F	560-029-360	O-Ring	2
1-G	675-062-115	End Cap Retainer	2
1-H	210-008-330	Safety Clip	1
1-I	530-031-550	Muffler	1
1-J	165-109-559	Muffler Cap	1
1-K	710-011-115	Self-Tapping Screw	4

For Pumps with Virgin PTFE coated hardware:

1	031-167-002	Air Valve Assembly	1
1-G	675-062-308	End Cap Retainer	2
1-J	710-011-308	Self Tapping Screw	4

(Includes all other items used on 031-166-000 above)

For Pumps with alternate Mesh or Sound Dampening Mufflers or Piped Exhaust:

1	031-169-000	Air Valve Assembly	1
---	-------------	--------------------	---

(Includes all items used on 031-167-000 above minus 1-H, 1-I and 1-J)

AIR DISTRIBUTION VALVE WITH STROKE INDICATOR OPTION SERVICING

To service the air valve first shut off the compressed air, bleed pressure from the pump, and disconnect the air supply line from the pump.

STEP #1: See COMPOSITE REPAIR PARTS DRAWING.

Using a 3/8" wrench or socket, remove the four hex flanged capscrews (item 12). Remove the air valve assembly from the pump.

STEP #2: Disassembly of the air valve.

To access the internal air valve components first remove the two end cap retainers (item 1-G) by inserting a small flat screwdriver into the two slotted grooves on the valve body and gently lifting the retainers out.

Next remove the two end caps (item 1-E) by grasping the pull tab with finger and thumb or pliers and tugging. Inspect the two o-rings (items 1-C and 1-F) on each end cap for wear or cuts. Replace the o-rings if necessary.

Remove the spool (part of item 1-B) from the sleeve. Be careful not to scratch or damage the outer diameter of the spool. Wipe spool with a soft clean cloth and inspect for scratches or abrasive wear.

Inspect the inner diameter of the sleeve (part of item 1-B) for dirt, scratches, or other contaminants. Remove the sleeve if needed and replace with a new sleeve and spool set (item 1-B). **Note:** The sleeve and spool set is match-ground to a specified clearance. Sleeves and spools cannot be interchanged.

STEP #3: Reassembly of the air distribution valve.

Install one end cap with o-rings (items 1-E, 1-C, and 1-F) into one end of the air valve body (item 1-A). Insert one end cap retainer (item 1-G) into the two smaller holes, align with groove in the end cap, and push until the closed end of the retainer is below the flat surface of the valve body.

Remove the new sleeve and spool set (item 1-B) from the plastic bag. Carefully remove the spool from the sleeve. Install the six o-rings (item 1-C) into the six grooves on the sleeve. Apply a light coating of grease to the o-rings before installing the sleeve into the valve body. Align the slots in the sleeve with the slots in the valve body. Insert the spool into the sleeve. Be careful not to scratch or damage the spool during installation. Push the spool in until the pin touches the end cap on the opposite end.

Install the remaining end cap with o-rings and retaining ring.

Fasten the air valve assembly (item 1) and gasket (item 23) to the pump, using the four hex flanged capscrews (item 12).

Connect the compressed air line to the pump. The pump is now ready for operation.

IMPORTANT: Remove the safety clip. The pump will not function properly until it is removed. The pump is now ready for operation.

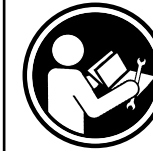

! IMPORTANT

Read these instructions completely, before installation and start-up. It is the responsibility of the purchaser to retain this manual for reference.

Failure to comply with the recommendations stated in this manual will damage the pump, and void factory warranty.

Pilot Valve Servicing, Assembly Drawing & Parts List

PILOT VALVE ASSEMBLY PARTS LIST

ITEM	PART NUMBER	DESCRIPTION	QTY
3	095-091-000	Pilot Valve Assembly	1
3-A	095-087-551	Valve Body	1
3-B	755-051-000	Sleeve (With O-rings)	1
3-C	560-033-379	O-ring (Sleeve)	6
3-D	775-055-000	Spool (With O-rings)	1
3-E	560-023-379	O-ring (Spool)	3
3-F	675-037-080	Retaining Ring	1

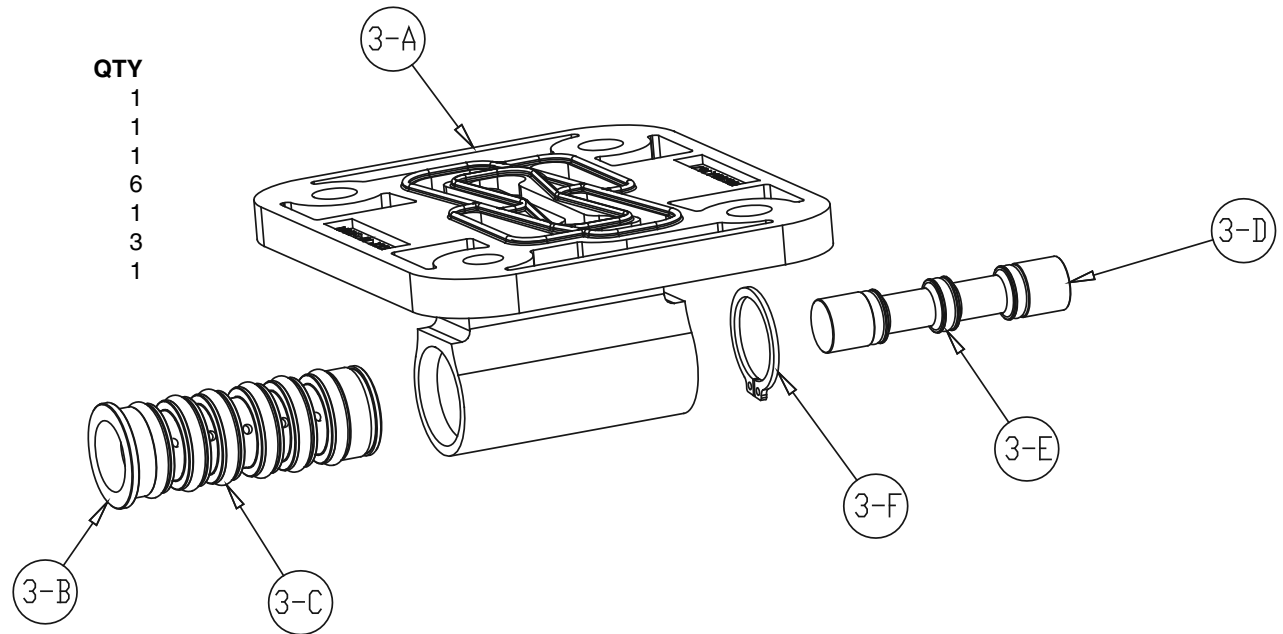

PILOT VALVE SERVICING

To service the pilot valve first shut off the compressed air supply, bleed the pressure from the pump, and disconnect the air supply line from the pump.

STEP #1: See pump assembly drawing.

Using a 7/16" wrench or socket, remove the four capscrews (item 12). Remove the air inlet cap (item 8) and air inlet gasket (item 18). The pilot valve assembly (item 3) can now be removed for inspection and service.

STEP #2: Disassembly of the pilot valve.

Remove the pilot valve spool (item 3-D). Wipe clean and inspect spool and o-rings for dirt, cuts or wear. Replace the o-rings and spool if necessary.

Remove the retaining ring (item 3-F) from the end of the sleeve (item 3-b) and remove the sleeve from the valve body (item 3-A). Wipe clean and inspect sleeve and o-rings for dirt, cuts or wear. Replace the o-rings and sleeve if necessary.

STEP #3: Re-assembly of the pilot valve.

Generously lubricate outside diameter of the sleeve and o-rings. Then carefully insert sleeve into valve body. Take CAUTION when inserting sleeve, not to shear any o-rings. Install retaining ring to sleeve. Generously lubricate outside diameter of spool and o-rings. Then carefully insert spool into sleeve. Take CAUTION when inserting spool, not to shear any o-rings. Use BP-LS-EP-2 multipurpose grease, or equivalent.

STEP #4: Re-install the pilot valve assembly into the intermediate.

Be careful to align the ends of the pilot valve stem between the plunger pins when inserting the pilot valve into the cavity of the intermediate.

Re-install the gasket, air inlet cap and capscrews. Connect the air supply to the pump. The pump is now ready for operation.

Solenoid Shifted Air Valve Drawing

Solenoid Shifted Air Valve Parts List

Item	Part Number	Description	Qty
4	114-023-551	Bracket, Intermediate	1
47	893-099-000	Solenoid Valve, NEMA4	1
48	219-001-000	Solenoid Coil, 24VDC	1
	219-004-000	Solenoid Coil, 24VAC/12VDC	1
	219-002-000	Solenoid Coil, 120VAC	1
	219-003-000	Solenoid Coil, 240VAC	1
49	241-001-000	Connector, Conduit	1
50	171-065-115	Capscrew, Flanged 1/4-20 x 1.004	1
52	618-050-150	Plug (Replaces item 7)	2

For Explosion Proof Solenoid Coils:

48	219-009-001	Solenoid Coil, 120VAC 60Hz	1
	219-009-002	Solenoid Coil, 240VAC 60Hz	1
	219-009-003	Solenoid Coil, 12VDC	1
	219-009-004	Solenoid Coil, 24VDC	1
	219-009-005	Solenoid Coil, 110VAC 50Hz	1
	219-009-006	Solenoid Coil, 230VAC 50Hz	1

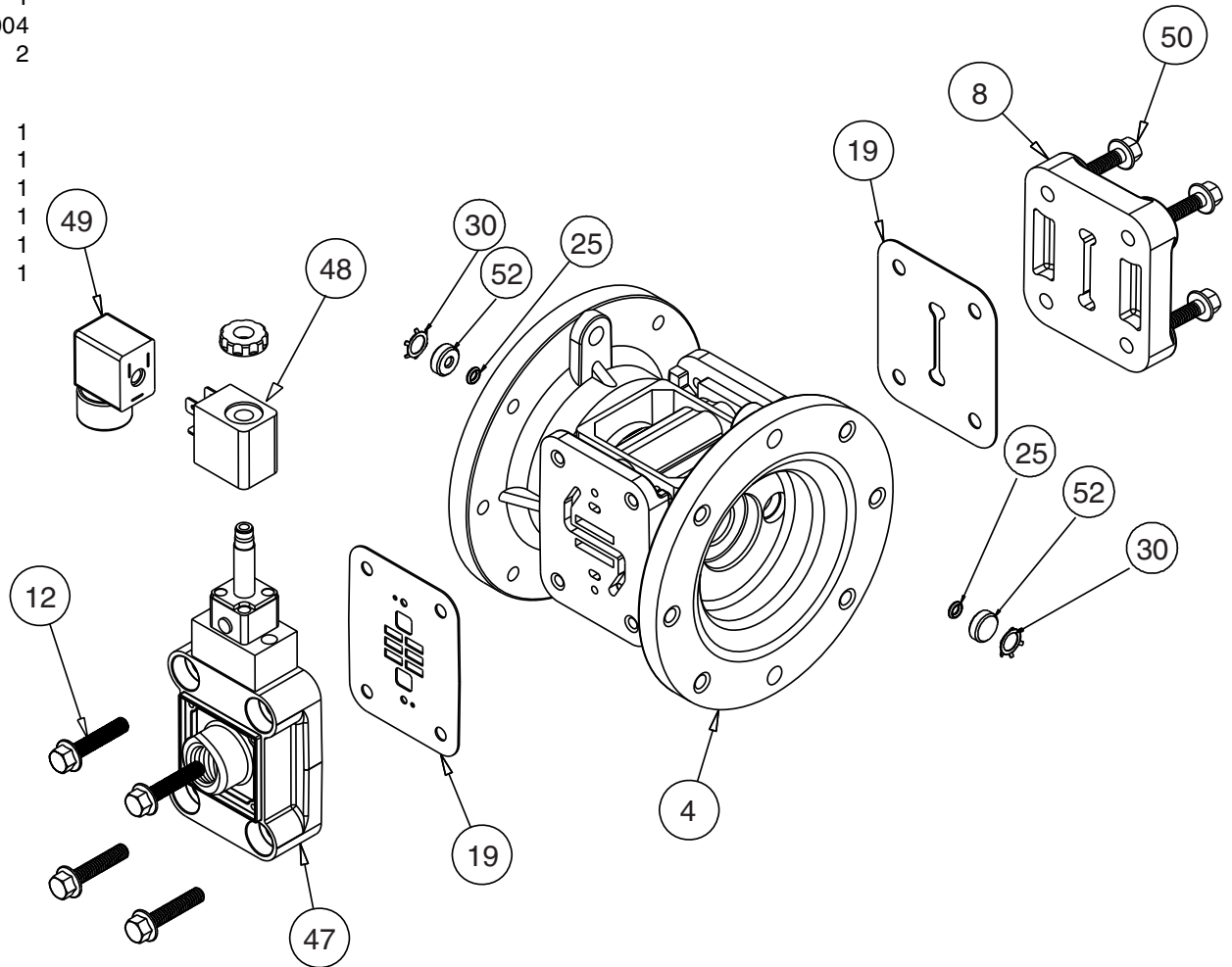

SOLENOID SHIFTED AIR DISTRIBUTION VALVE OPTION

Warren Rupp's solenoid shifted, air distribution valve option utilizes electrical signals to precisely control your SANDPIPER's speed. The solenoid coil is connected to a customer - supplied control. Compressed air provides the pumping power, while electrical signals control pump speed (pumping rate).

OPERATION

The Solenoid Shifted SANDPIPER has a solenoid operated, air distribution valve in place of the standard SANDPIPER's pilot operated, air distribution valve. Where a pilot valve is normally utilized to cycle the pump's air distribution valve, an electric solenoid is utilized. As the solenoid is powered, one of the pump's air chambers is pressurized while the other chamber is exhausted. When electric power is turned off, the solenoid shifts and the pressurized chamber is exhausted while the other chamber is pressurized. By alternately applying and removing power to the solenoid, the pump cycles much like a standard SANDPIPER pump, with one exception. This option provides a way to precisely control and monitor pump speed.

BEFORE INSTALLATION

Before wiring the solenoid, make certain it is compatible with your system voltage.

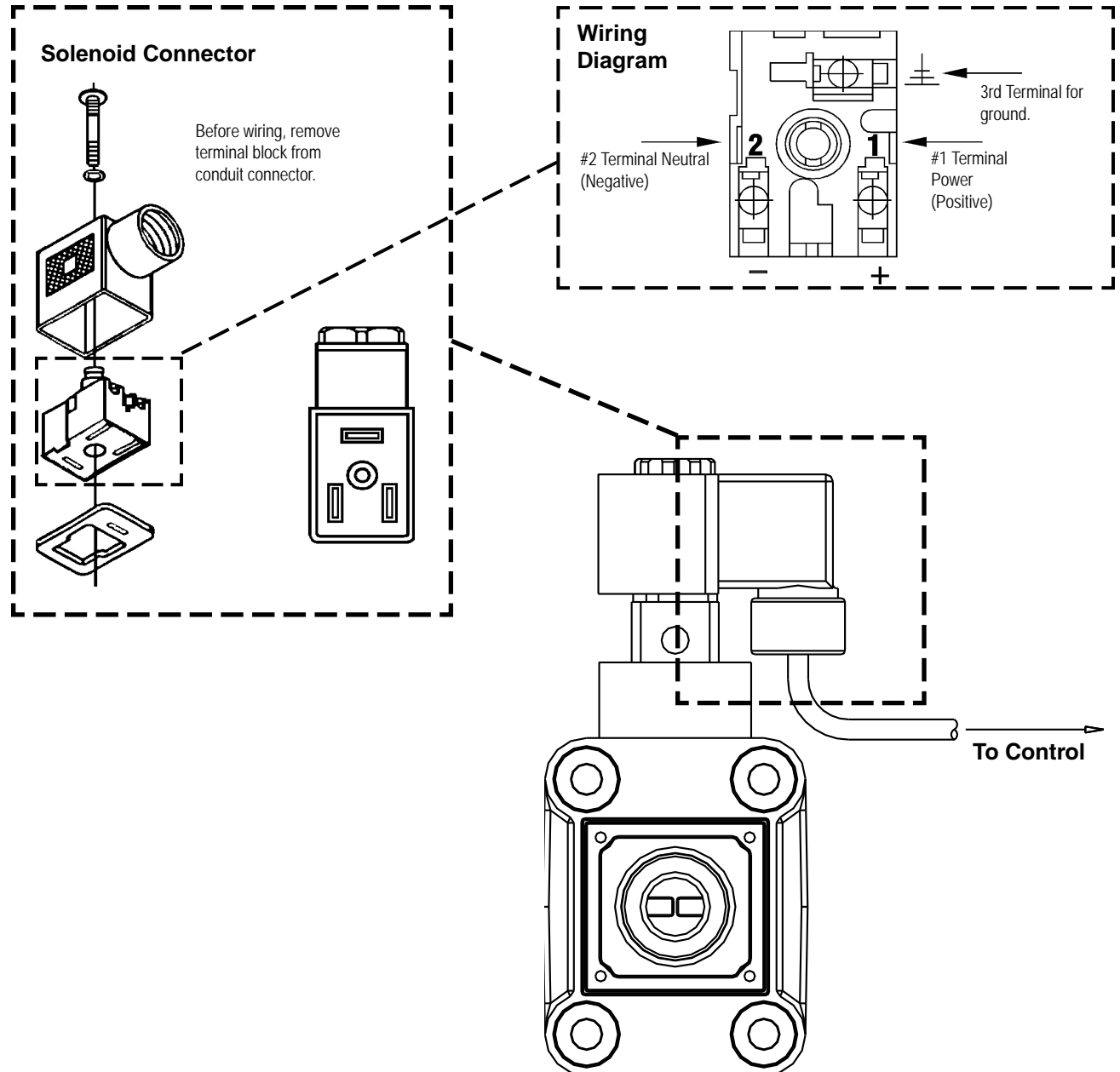

Intermediate Drawing

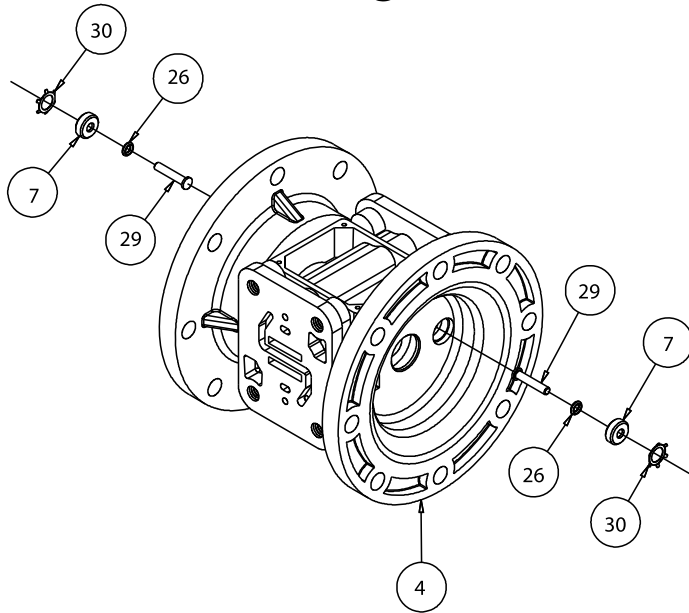

INTERMEDIATE ASSEMBLY REPAIR PARTS LIST

Item	Part Number	Description	Qty
4	114-023-551	Bracket, Intermediate	1
7	135-036-506	Bushing, Plunger	2
25	560-001-360	O-Ring	2
28	620-019-115	Plunger, Actuator	2
30	675-042-115	Ring, Retaining*	2

***NOTE:** It is recommended that when plunger components are serviced, new retaining rings be installed.

Intermediate Servicing

ACTUATOR PLUNGER SERVICING

To service the actuator plunger first shut off the compressed air supply, bleed the pressure from the pump, and disconnect the air supply line from the pump.

Step #1: See PUMP ASSEMBLY DRAWING.

Using a 3/8" wrench or socket, remove the four capscrews (items 12). Remove the air inlet cap (item 8) and air inlet gasket (item 20). The pilot valve assembly (item 3) can now be removed.

Step #2: Servicing the actuator plungers.

See PUMP ASSEMBLY DRAWING.

The actuator plungers (items 28) can be reached through the stem cavity of the pilot valve in the intermediate bracket (item 4). To service bushings, o-rings and retaining rings, see Intermediate Drawing.

Remove the plungers (items 28) from the bushings (item 7) in each end of the intermediate cavity. Inspect for wear or damage. Replace plunger as needed. Apply a light coating of grease to each o-ring and re-install the plungers in to the bushings. Push the plungers in as far as they will go.

Step #3: Re-install the pilot valve assembly into the intermediate assembly.

Be careful to align the ends of the stem between the plungers when inserting the stem of the pilot valve into the cavity of the intermediate.

Re-install the gasket (item 20), air inlet cap (item 8) and capscrews (items 12).

Connect the air supply to the pump. The pump is now ready for operation.

PLUNGER BUSHING, O-RING, AND RETAINING RING SERVICING

To service the plunger bushing components first remove the two retaining rings (items 30) using a small flat screwdriver. ***Note:** It is recommended that new retaining rings be installed.

Next remove the two plunger bushings (items 7). Inspect the bushings for wear or scratches. Replace the bushings as necessary.

Inspect the two o-rings (25) for cuts and/or wear.

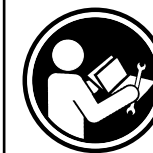

! IMPORTANT

Read these instructions completely, before installation and start-up. It is the responsibility of the purchaser to retain this manual for reference. Failure to comply with the recommendations stated in this manual will damage the pump, and void factory warranty.

Modular Check Ball Valve Drawing

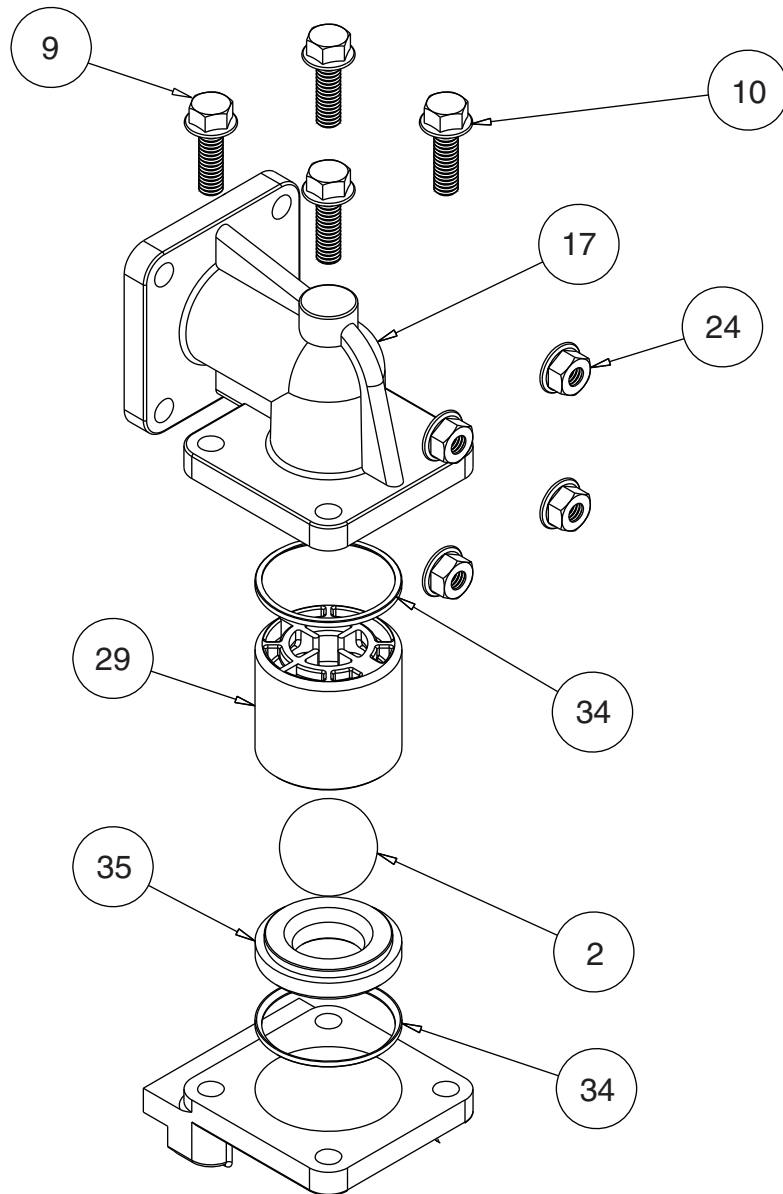

MODULAR CHECK BALL VALVE SERVICING

Before servicing the check valves, first shut off the suction line and then the discharge line to the pump. Next, shut off the compressed air supply, bleed air pressure from the pump, and disconnect the air supply line from the pump. Drain any remaining fluid from the pump. The pump can now be removed for service.

To access the modular check valve, remove the elbows (items 17 from pump composite repair parts drawing). Use a 1/2" wrench or socket to remove the fasteners. Once the elbows are removed, the modular check valves can be seen in the cavities of the outer chamber (items 14).

Next remove the check valve seal (item 34). Inspect the seal for cuts or pinched areas. Replace seal as needed.

Disassemble the component parts of each modular check valve. Inspect the check valve retainer (item 29) for cuts, abrasive wear, or embedded materials. Replace as needed.

Inspect the check balls (items 2) for wear, abrasion, or cuts on the spherical surface. The check valve seats (items 35) should be inspected for cuts, abrasive wear, or embedded material on the surfaces of both the external and internal chambers. The spherical surface of the check balls must seat flush to the surface of the inner chamfer on the check valve seats for the pump to operate to peak efficiency. Replace any worn or damaged parts as necessary.

Remove the check valve seal (item 34). Inspect the seal for cuts or pinched areas. Replace seal as needed.

RE-ASSEMBLE THE MODULAR CHECK VALVES.

Place a check valve seal (item 34) into the cavity of the outer chamber (item 14). Make sure the chamfer side of the seal faces out. Insert the modular check valve into the outer chamber with the retainer facing up. Install a check valve seal (item 34). Make sure the chamfer side of the seals face the chamfer on the check valve seat or retainer.

The pump can now be reassembled, reconnected and returned to operation.



! IMPORTANT
Read these instructions completely, before installation and start-up. It is the responsibility of the purchaser to retain this manual for reference. Failure to comply with the recommendations stated in this manual will damage the pump, and void factory warranty.

Diaphragm Service Drawing

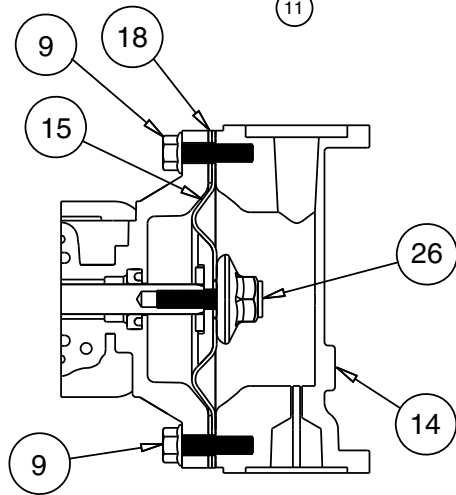
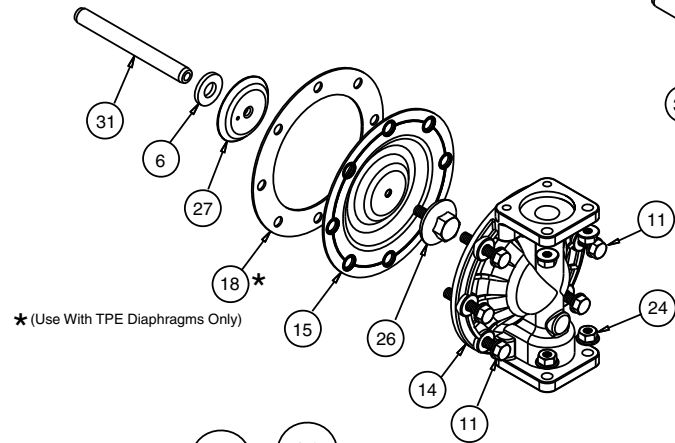

Diaphragm Orientation

Install diaphragm and spacer as shown above.

Diaphragm Service Drawing, with Overlay

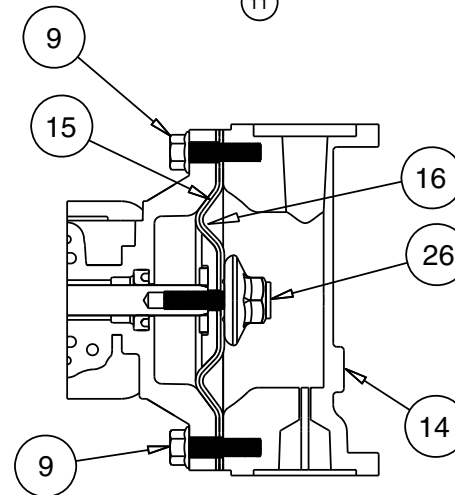
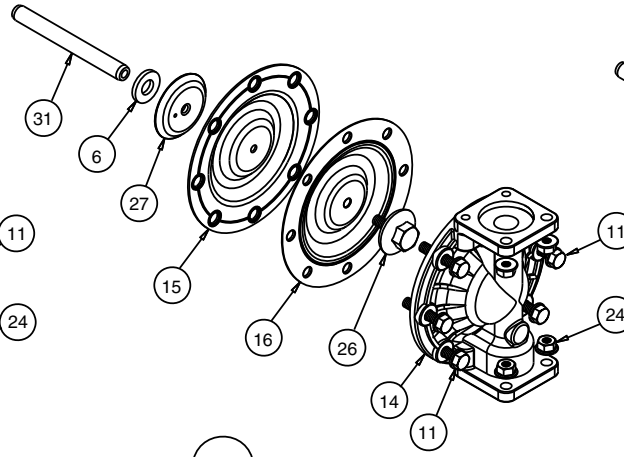

Diaphragm Orientation

Install diaphragm and overlay as shown above.

Diaphragm Service Drawing with One-Piece Bonded

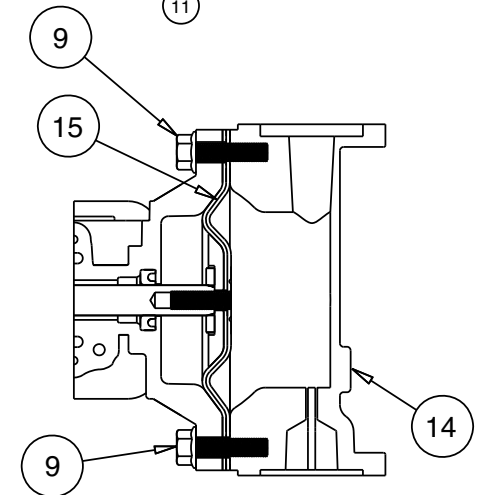
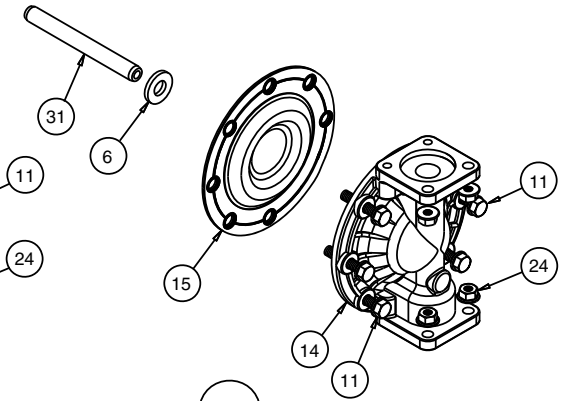

Diaphragm Orientation

Install diaphragm (286.116.000 only) as shown above.

DIAPHRAGM SERVICING

To service the diaphragms first shut off the suction, then shut off the discharge lines to the pump. Shut off the compressed air supply, bleed the pressure from the pump, and disconnect the air supply line from the pump. Drain any remaining liquid from the pump.

Step #1: See the pump composite repair parts drawing, and the diaphragm servicing illustration.

Using a 1/2" wrench or socket, remove the 16 capscrews (items 9 & 10), and nuts that fasten the elbows (items 17) to the outer chambers (items 14). Remove the elbows with the manifolds and spacers attached.

Step #2: Removing the outer chambers.

Using a 1/2" wrench or socket, remove the 16 capscrews (items 9 & 11), and nuts that fasten the outer chambers, diaphragms, and intermediate bracket (items 4) together.

Step #3: Removing the diaphragm assemblies.

Use a 3/4" (19mm) wrench or six pointed socket to remove the diaphragm assemblies (outer plate, diaphragm, and inner plate) from the diaphragm rod (item 31) by turning counterclockwise.

Insert a 6-32 set screw into the smaller tapped hole in the inner diaphragm plate (item 27). Insert the protruding stud and the 6-32 fastener loosely into a vise. Use a

3/4" wrench or socket to remove the outer diaphragm plate (item 26) by turning counterclockwise. Inspect the diaphragm (item 15) for cuts, punctures, abrasive wear or chemical attack. Replace the diaphragms if necessary.

Step #4: Installing the diaphragms.

Push the threaded stud of the outer diaphragm plate through the center hole of the diaphragm. Thread the inner plate clockwise onto the stud. Use a torque wrench to tighten the diaphragm assembly together to 90 in Lbs. (10.17 Newton meters) 120 in lbs. Santoprene (13.56 Newton meters). Allow a minimum of 15 minutes to elapse after torquing, then re-torque the assembly to compensate for stress relaxation in the clamped assembly.

Step #5: Installing the diaphragm assemblies to the pump.

Make sure the bumper (item 6) is installed over the diaphragm rod.

Thread the stud of the one diaphragm assembly clockwise into the tapped hole at the end of the diaphragm rod (item 31) until the inner diaphragm plate is flush to the end of the rod. Insert rod into pump.

Align the bolt holes in the diaphragm with the bolt pattern in the inner chamber (item 4). Make sure the molded directional arrows on the diaphragm point vertically.

Fasten the outer chamber (item 14) to the pump, using the capscrews (items 9 & 11), hex nuts and flat washers.

On the opposite side of the pump, pull the diaphragm rod out as far as possible. Make sure the bumper (item 6) is installed over the diaphragm rod.

Thread the stud of the remaining diaphragm assembly clockwise into the tapped hole at the end of the diaphragm rod (item 31) as far as possible and still allow for alignment of the bolt holes in the diaphragm with the bolt pattern in the inner chamber. The molded directional arrows on the diaphragm must point vertically.

Fasten the remaining outer chamber (item 14) to the pump, using the capscrews (items 9 & 11) and nuts.

Step #6: Re-install the elbow/spacer/manifold assemblies to the pump, using the capscrews (items 9 & 10) and nuts.

The pump is now ready to be re-installed, connected and returned to operation.

OVERLAY DIAPHRAGM SERVICING

The PTFE overlay diaphragm (item 16) is designed to fit snugly over the exterior of the standard TPE diaphragm (item 15).

The molded directional arrows on the overlay diaphragm must point vertically.

Follow the same procedures described for the standard diaphragm for removal and installation.

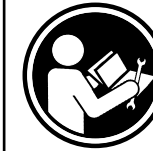

! IMPORTANT

Read these instructions completely, before installation and start-up. It is the responsibility of the purchaser to retain this manual for reference. Failure to comply with the recommendations stated in this manual will damage the pump, and void factory warranty.

ONE PIECE DIAPHRAGM SERVICING

(Bonded PTFE with integral plate)

The One Piece diaphragm has a treated stud installed in the integral plate at the factory. The inner diaphragm plate has a through hole instead of a threaded hole.

Place the inner plate over the diaphragm stud and thread the first diaphragm / inner plate onto the diaphragm rod only until the inner plate contacts the rod. Do not tighten.

A small amount of grease may be applied between the inner plate and the diaphragm to facilitate assembly.

Insert the diaphragm / rod assembly into the pump and install the outer chamber. Turn the pump over and thread the second diaphragm / inner plate onto the diaphragm rod. Turn the diaphragm until the inner plate contacts the rod and hand tighten the assembly. Continue tightening until the bolt holes align with the inner chamber holes. **DO NOT LEAVE THE ASSEMBLY LOOSE.**

PUMPING HAZARDOUS LIQUIDS

When a diaphragm fails, the pumped liquid or fumes enter the air end of the pump. Fumes are exhausted into the surrounding environment. When pumping hazardous or toxic materials, the exhaust air must be piped to an appropriate area for safe disposal. See illustration #1 at right.

This pump can be submerged if the pump materials of construction are compatible with the liquid being pumped. The air exhaust must be piped above the liquid level. See illustration #2 at right. Piping used for the air exhaust must not be smaller than 1/2" (1.27 cm) diameter. Reducing the pipe size will restrict air flow and reduce pump performance. When the pumped product source is at a higher level than the pump (flooded suction condition), pipe the exhaust higher than the product source to prevent siphoning spills. See illustration #3 at right.

CONVERTING THE PUMP FOR PIPING THE EXHAUST AIR

The following steps are necessary to convert the pump to pipe the exhaust air away from the pump.

Use a Phillips screwdriver to remove the four self-tapping screws (item 1-H).

Remove the muffler cap and muffler (items 1-G and 1-F). The 3/8" NPT molded threads in the air distribution valve body (item 1-A).

Piping or hose may now be installed. **IMPORTANT INSTALLATION NOTE:** The manufacturer recommends installing a flexible hose or connection between the pump and any rigid plumbing. This reduces stresses on the molded plastic threads of the air exhaust port. Failure to do so may result in damage to the air distribution valve body.

Any piping or hose connected to the pump's air exhaust port must be physically supported. Failure to support these connections could also result in damage to the air distribution valve body.

Exhaust Conversion Drawing

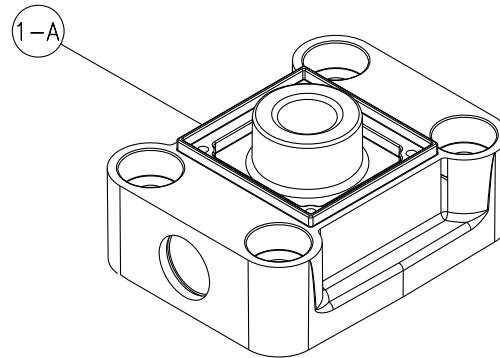

CONVERTED EXHAUST ILLUSTRATION

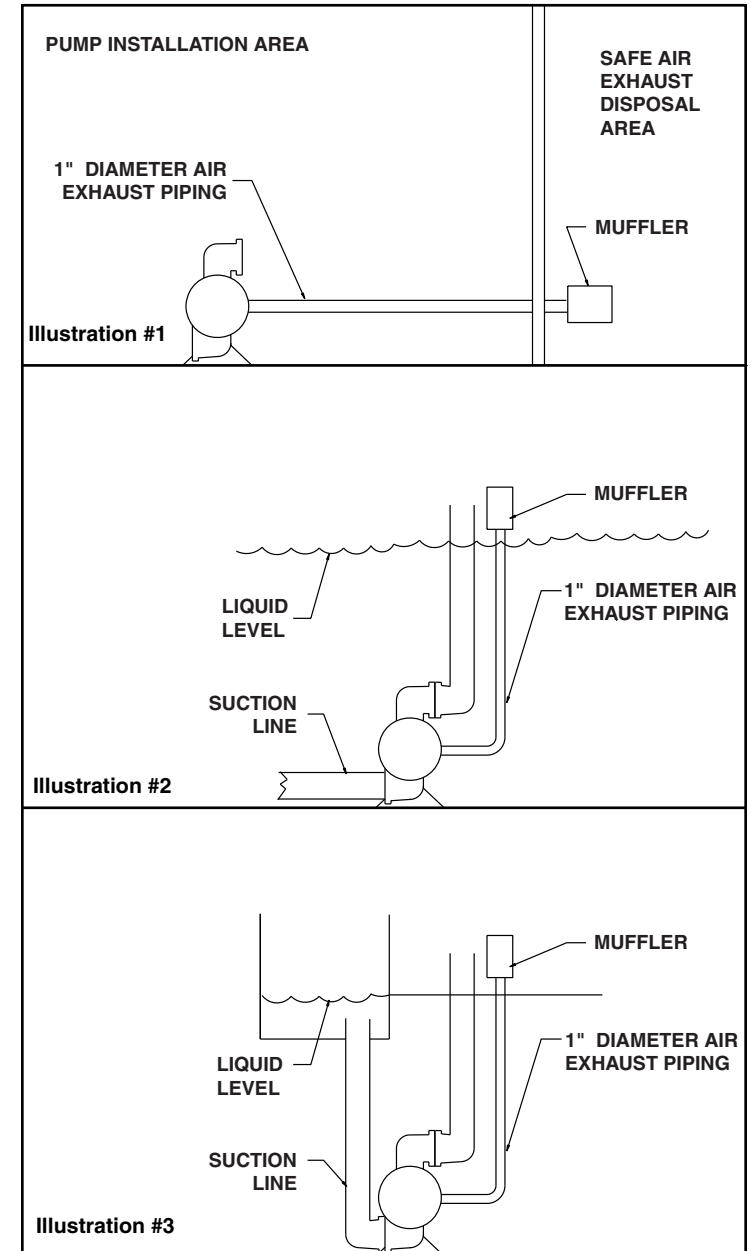

Pulse Output Kit Drawing

PULSE OUTPUT KIT OPTION

This pump can be fitted with a Pulse Output Kit. This converts the mechanical strokes of the pump to an electrical signal which interfaces with the Stroke Counter/ Batch Controller or user control devices such as a PLC.

See the individual kits listed on the Pump Repair Parts List for further information.

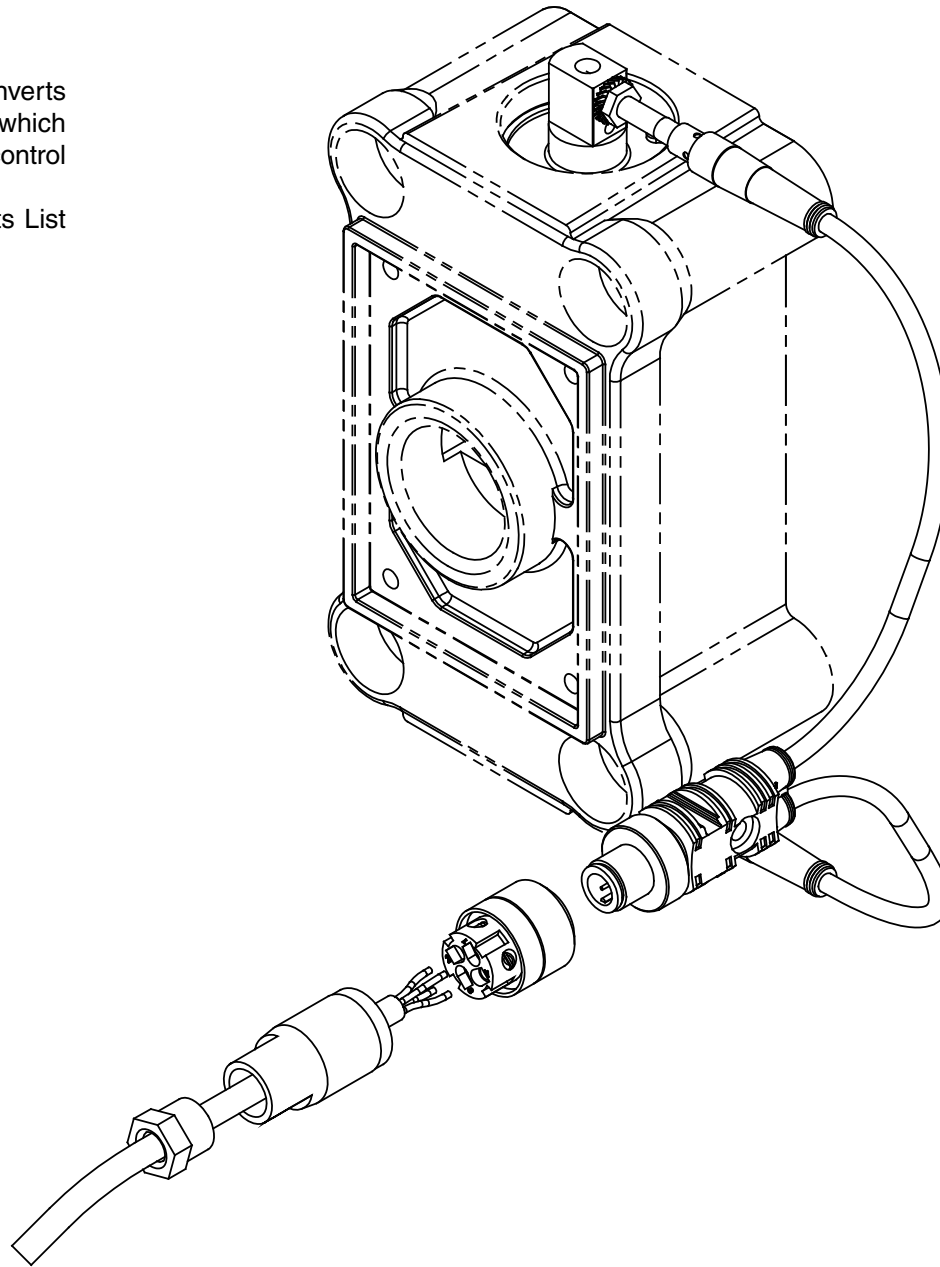

Optional Muffler Configurations, Drawing



OPTION 0

530-031-550 Integral Muffler uses (1) Cap and (4) 706-027-115 Machine Screw to hold it in place.

OPTION 1

530-024-000 Sound Dampening Muffler screws directly into the Air Valve body. This muffler is equipped with a porous plastic element.

OPTION 2

530-023-000 Mesh Muffler screws directly into the Air Valve Body. This muffler is equipped with a metal element.



OPTION 6

530-035-000 Metal Muffler screws directly into the Air Body.

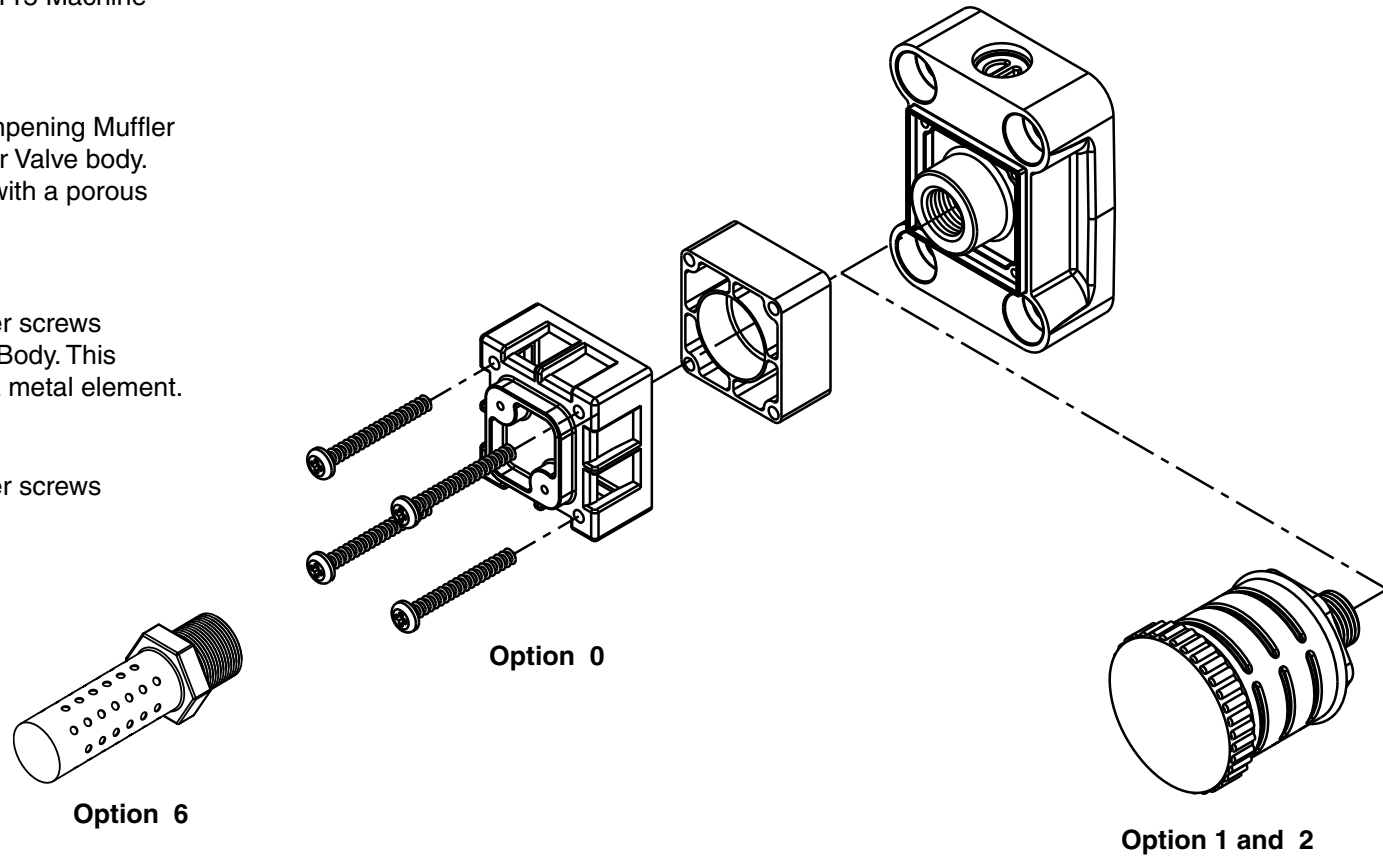

Declaration of Conformity



**WARREN
RUPP®**

IBEX
FLUID & METERING

Declaration of Conformity

Warren Rupp, Inc., 800 North Main Street, Mansfield, Ohio, certifies that Air-Operated Double Diaphragm Pumps Series: HDB, HDF, M Non-Metallic, S Non-Metallic, M Metallic, S Metallic, Containment Duty, Gas, UL, High Pressure, W, Submersible and Tranquilizers comply with the European Community Directive 98/37/EC, Safety of Machinery. This product has used EN 809, Pumps and Pump Units for Liquids - Common Safety Requirements harmonized standard to verify conformance.

David Roseberry

Signature of authorized person

October 20, 2005

Date of issue

David Roseberry

Printed name of authorized person

Engineering Manager

Title

CE



Declaration of Conformity