



说明书

VLT[®] HVAC Basic Drive
多泵控制器

目录

1.1 多泵控制器	2
1.1.1 系统状态和运行	2
1.1.2 启动/停止条件	3
1.2 安装	3
1.2.1 控制端子	3
1.2.2 电气概述	4
1.3 规格	5
1.3.1 产品一般规范	5
1.4 参数概述	6

1.1 多泵控制器



图 1.1

多泵控制器用于需要在广泛的动态范围内保持某个压力（“压力差”）或水平的泵应用。在较大的速度变化范围内使用大型泵并不是一种理想的解决方案，因为泵的效率低，并且泵的实际运行速度只能达到其额定满载速度的 25%。

在多泵控制器中，变频器通过控制变速电动机来实现对变速泵（变频）的控制，它最多可以切入 2 台另外的恒速泵并控制其开/关。它通过改变初始泵的速度来实现对整个系统的可变速度控制。借此不仅能保持恒定压力，而且还可以避免压力冲击，从而降低泵系统的系统应力和运行噪音。

固定变频器

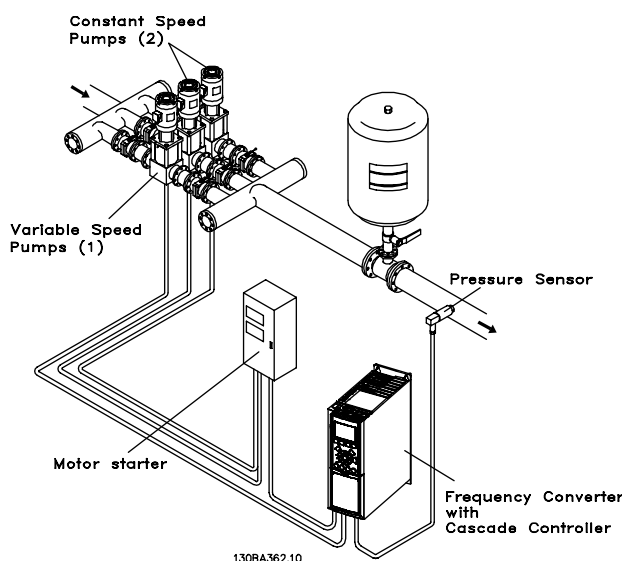
电动机必须具有相同的规格。多泵控制器允许变频器借助变频器内置的 2 个继电器和端子 27、29（数字输入/数字输出）来控制 5 台之多相同规格的泵。当变频泵直接与变频器相连时，另外 4 台泵将由内置的 2 个继电器和端子 27、29（数字输入/数字输出）来控制。当变频泵固定时，无法选择变频泵轮换。

变频泵轮换

电动机必须具有相同的规格。该功能使得变频器可以交替用于系统中的泵（当 25-57 Relays per Pump =1，最大泵数为 4。当 25-57 Relays per Pump =2，最大泵数为 3）。这种工作模式可以使各台泵的运行时间基本相等，因此有助于降低泵的维护要求、提高可靠性以及延长系统的使用寿命。变频泵的轮换可以根据命令信号或在切入（添加滞后泵）时发生。

这种命令可以是手动轮换或轮换事件信号。如果选择了轮换事件，则每当该事件发生时都会发生变频泵轮换。选项包括：每当某个轮换计时器期满时；或者当变频泵进入睡眠模式时。切入是根据系统的实际负载来确定的。

当 25-55 Alternate if Load $\leq 50\%$ = 1，如果负载 $>50\%$ ，则不会发生轮换。如果负载 $\leq 50\%$ ，则发生轮换。

当 25-55 Alternate if Load $\leq 50\%$ = 0，不论负载如何，都将发生轮换。总的泵容量是变频泵与滞后恒速泵的容量和。

带宽管理

在多泵控制系统中，为了避免恒速泵频繁开关，所要求的系统压力保持在一个带宽内，而不是维持在某个恒定水平。切入带宽提供了所要求的运行带宽。一旦系统压力发生较大并且较快的变化，立即切泵带宽便会取代切入带宽，以防止系统立即对瞬时的压力变化作出响应。通过设置一个立即切泵带宽计时器，可以防止在系统压力尚未稳定并且尚未建立正常控制之前发生切入。

如果变频器在多泵控制器被启用并在正常运行时发出了一个跳闸报警，则会通过切入和停止恒速泵来保持系统的压力差。为避免频繁的切入和停止并且尽量减小压力波动，系统将使用一个更宽的恒速带宽，而不是切入带宽。

1.1.1 系统状态和运行

仅当变频泵在工作时，变频器才可能转入睡眠模式。启用多泵控制器后，在 LCP 上将通过 25-81 Pump Status 和 25-80 Cascade Status 显示每台泵以及多泵控制器的运行状态。所显示的多泵控制器信息包括：

- 泵的状态。这是分配给每台泵的继电器的状态读数。该信息显示了泵的下述状态：禁用、关闭、依靠变频器运行或依靠电网/电动机启动器运行。
- 多泵状态。这是多泵控制器的状态读数。该状态信息包括：多泵控制器被禁用、所有泵正在运行、恒速泵切入/停止以及变频泵发生轮换。

1.1.2 启动/停止条件

分配给数字输入的命令。 请参阅参数组 5-1* *Digital Inputs*。

	变频泵 (变频)	恒速泵 (滞后)
启动 (系统启动/停止)	加速 (如果已停止并且存在请求)	切入 (如果已停止并且存在请求)
变频泵启动	加速 (如果激活了“系统启动”)	不受影响
惯性停车 (紧急停止)	惯性停车	断开 (对应继电器, 端子 27/29 和 42/45)
外部互锁	惯性停车	断开 (内置继电器被去能)

表 1.1

LCP 上按钮的功能:

	变频泵 (变频)	恒速泵 (滞后)
[Hand On] (手动启动)	加速 (如果已在正常停止命令下停止) 或保持运行 (如果在运行)	停止 (如果在运行)
[Off] (停止)	减速	正在停止
[Auto On] (自动启动)	根据端子或串行总线的命令启动和停止。多泵控制器只能在变频器处于“自动启动”模式时工作	切入/停止

表 1.2

1.2 安装

1.2.1 控制端子

图 1.2 显示了变频器的所有控制端子。通过施加启动信号 (端子 18), 端子 12 与 27 之间的连接以及模拟参考值 (端子 53 或 54 和 55) 可以使变频器运行。



图 1.2 控制端子

1.2.2 电气概述

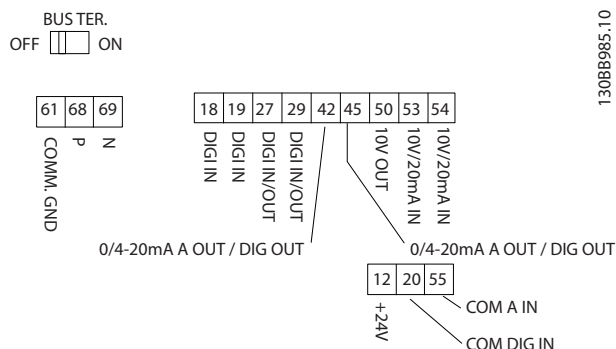

图 1.3

注意

在下述设备上无 UDC- 和 UDC+:
IP20 380-480 V 30-90 kW

1.3 规格

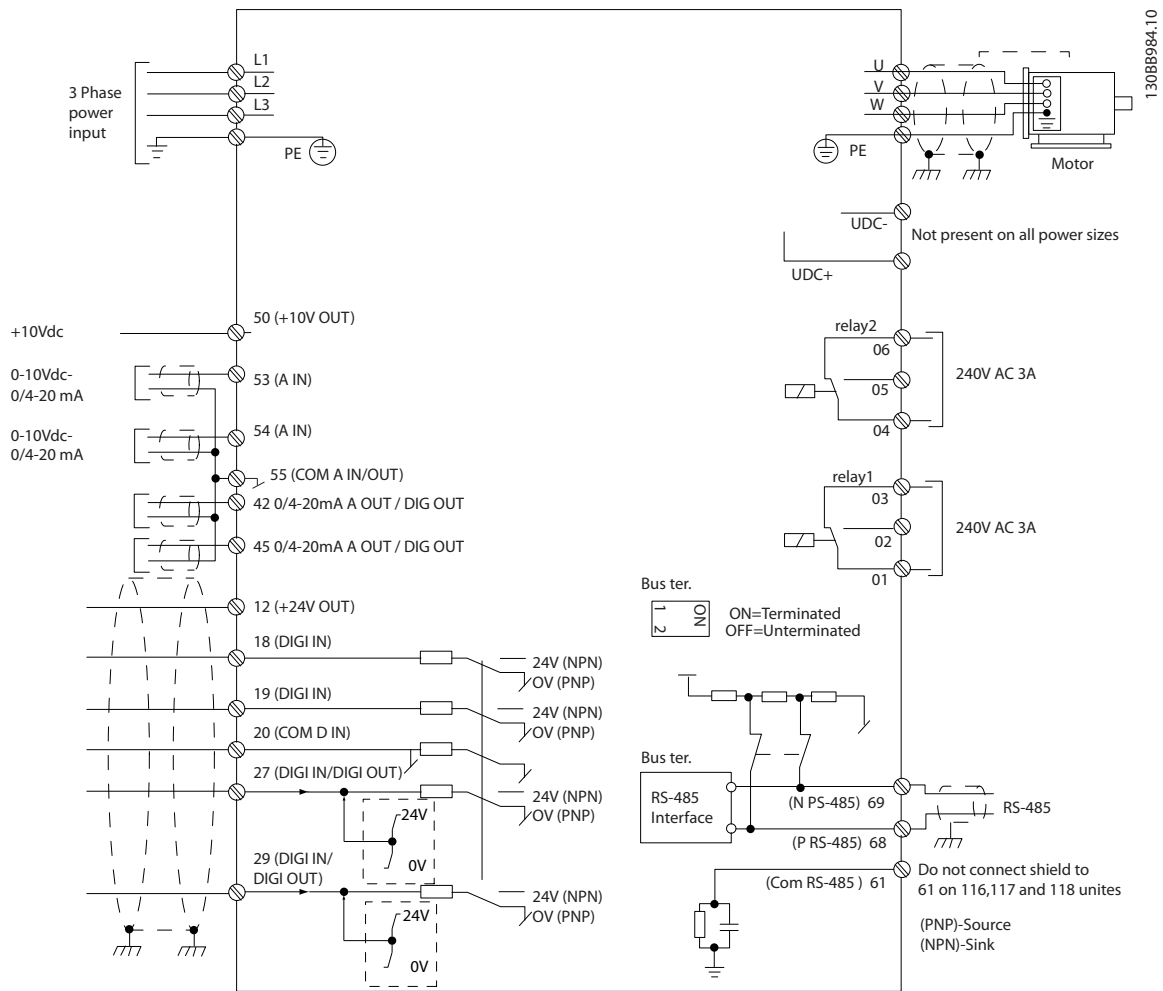
1.3.1 产品一般规范

变频器	PK37	PK75	P1K5	P2K2	P3K0	P4K0	P5K5	P7K5	P11K
典型主轴输出 (kW)	0.37	0.75	1.5	2.2	3.0	4.0	5.5	7.5	11
IP 20 机架	H1	H1	H1	H2	H2	H2	H3	H3	H4
射频干扰级别	A1	A1	A1	A1	A1	A1	A1	A1	A1
PCB	有涂层	有涂层	有涂层	有涂层	有涂层	有涂层	有涂层	有涂层	有涂层
变频器	P15K	P18K	P22K	P30K	P37K	P45K	P55K	P75K	P90K
典型主轴输出 (kW)	15	18	22	30	37	45	55	75	90
IP 20 机架	H4	H5	H5	H6	H6	H6	H7	H7	H8
射频干扰级别	A1	A1	A1	A1	A1	A1	A1	A1	A1
PCB	有涂层	有涂层	有涂层	有涂层	有涂层	有涂层	有涂层	有涂层	有涂层

表 1.3

1.4 参数概述

参数概述			
0-** Operation / Display	*[1] Set-up 1	[173] ft WG	1-20 Motor Power
0-0* Basic Settings	[2] Set-up 2	[180] HP	[2] 0.12 kW - 0.16 Hp
0-01 Language	[9] Multi Set-up	0-31 Custom Readout Min Value	[3] 0.18 kW - 0.25 Hp
*[0] English	0-11 Programming Set-up	0.00 - 1,000,000.0, * 0.00	[4] 0.25 kW - 0.33 Hp
[1] Deutsch	[1] Set-up 1	0-32 Custom Readout Max Value	[5] 0.37 kW - 0.50 Hp
[2] Francais	[2] Set-up 2	0.00 - 1,000,000.0, *	[6] 0.55 kW - 0.75 Hp
[3] Dansk	*[9] Active Set-up	100.00	[7] 0.75 kW - 1.00 Hp
[4] Espanol	0-12 Link Setups	0-37 Display Text 1	[8] 1.10 kW - 1.50 Hp
[5] Italiano	[0] Not linked	0-38 Display Text 2	[9] 1.50 kW - 2.00 Hp
[28] Portuguese	*[20] Linked	0-39 Display Text 3	[10] 2.20 kW - 3.00 Hp
[255] No Text	0-3* LCP Readout	0-4* LCP Keypad	[11] 3.00 kW - 4.00 Hp
0-03 Regional Settings	0-30 Custom Readout Unit	0-40 [Hand on] Key on LCP	[12] 3.70 kW - 5.00 Hp
*[0] International	[0] None	[0] Disabled	[13] 4.00 kW - 5.40 Hp
[1] US	*[1] %	*[1] Enabled	[14] 5.50 kW - 7.50 Hp
0-04 Operating State at Power-up	[5] PPM	0-42 [Auto on] Key on LCP	[15] 7.50 kW - 10.0 Hp
*[0] Resume	[10] 1/Min	[0] Disabled	[16] 11.00 kW - 15.00 Hp
[1] Forced stop, ref=old	[11] RPM	*[1] Enabled	[17] 15.00 kW - 20 Hp
0-06 GridType	[12] Pulse/s	[0] Disabled	[18] 18.5 kW - 25 Hp
0] 200-240 V/50 Hz/IT-grid	[20] l/s	*[1] Enabled	[19] 22 kW - 30 Hp
[1] 200-240 V/50 Hz/Delta	[21] l/min	0-44 [Off / Reset] Key on LCP	[20] 30 kW - 40 Hp
[2] 200-240 V/50 Hz	[22] l/h	[0] Disable All	[21] 37 kW-50 Hp
[10] 380-440 V/50 Hz/IT-grid	[23] m3/s	*[1] Enable All	[22] 45 kW-60 Hp
[11] 380-440 V/50 Hz/Delta	[24] m3/min	[7] Enable Reset Only	[23] 55 kW-75 Hp
[12] 380-440 V/50 Hz	[25] m3/h	0-5* Copy/Save	[24] 75 kW-100 Hp
[20] 440-480 V/50 Hz/IT-grid	[30] kg/s	0-50 LCP Copy	[25] 90 kW-120 Hp
[21] 440-480 V/50 Hz/Delta	[31] kg/min	*[0] No copy	[26] 110 kW-150 Hp
[22] 440-480 V/50 Hz	[32] kg/h	[1] All to LCP	1-22 Motor Voltage
[30] 525-600 V/50 Hz/IT-grid	[33] t/min	[2] All from LCP	50 - 1000 V
[31] 525-600 V/50 Hz/Delta	[34] t/h	[3] Size indep. from LCP	1-23 Motor Frequency
[32] 525-600 V/50 Hz	[40] m/s	0-51 Set-up Copy	20 - 400, *(50) Hz
[100] 200-240 V/60 Hz/IT-grid	[41] m/min	*[0] No copy	1-24 Motor Current
[101] 200-240 V/60 Hz/Delta	[45] m	[1] Copy from setup 1	0.01 - (26.00), [A]
[102] 200-240 V/60 Hz	[60] Degree Celsius	[2] Copy from setup 2	1-25 Motor Nominal Speed
[110] 380-440 V/60 Hz/IT-grid	[70] mbar	[9] Copy from Factory setup	100 rpm - 6000 rpm,
[111] 380-440 V/60 Hz/Delta	[71] bar	0-6* Password	1-29 Automatic Motor Adaption ()
[112] 380-440 V/60 Hz	[72] Pa	0-60 Main Menu Password	*[0] Off
[120] 440-480 V/60 Hz/IT-grid	[73] kPa	0 - 999, * 0	[1] Enable Complete
[121] 440-480 V/60 Hz/Delta	[74] m Wg	1-** Load and Motor	[2] Enable Reduced
[122] 440-480 V/60 Hz	[80] kW	1-0* General Settings	1-3* Adv. Motor Data I
[130] 525-600 V/60 Hz/IT-grid	[120] GPM	1-00 Configuration Mode	1-30 Stator Resistance (Rs)
[131] 525-600 V/60 Hz/Delta	[121] gal/s	*[0] Open loop	0.000 ohm - 99.990 ohm
[132] 525-600 V/60 Hz	[122] gal/min	[3] Closed loop	1-33 Stator Leakage Reactance (X1)
[0] Off	[123] gal/h	1-01 Motor Control Principle	0.000 ohm - 999.900 ohm
*[1] On	[124] CFM	[0] U/f	1-35 Main Reactance (Xh)
0-1* Set-up Operations	[127] ft3/h	*[1] VVC+	0.00 - 999.90 ohm
0-10 Active Set-up	[140] ft/s	1-03 Torque Characteristics	1-39 Motor Poles
	[141] ft/min	*[1] Variable torque	2 - 100, * 4
	[160] Degree Fahr	[3] Auto Energy Optim.	
	[170] psi	1-06 Clockwise Direction	
	[171] lb/in2	*[0] Normal	
	[172] in WG	[1] Inverse	

表 1.4

参数概述			
<p>1-4* Adv. Motor Data II</p> <p>1-42 Motor Cable Length 0 - 150, * 50m</p> <p>1-43 Motor Cable Length Feet 0 - 431, * 144</p> <p>1-5* Load Indep. Setting</p> <p>1-50 Motor Magnetisation at Zero Speed 0 - 300, * 100%</p> <p>1-52 Min Speed Normal Magnetising [Hz] 0.0 - 10.0, * 0.0</p> <p>1-55 U/f Characteristic - U 0 - 999 V, *0V</p> <p>1-56 U/f Characteristic - F 0 - 400 Hz, *(0)</p> <p>1-6* Load Depend. Setting</p> <p>1-62 Slip Compensation -400 - 399%, * 0%</p> <p>1-63 Slip Compensation Time Constant 0.05 - 5.00 s, * 0.10</p> <p>1-64 Resonance Dampening 0 - 500%, * 100</p> <p>1-65 Resonance Dampening Time Constant 0.001 - 0.050 s, * 0.005</p> <p>1-7* Start Adjustments</p> <p>1-71 Start Delay 0.0 - 10.0 s, * 0.0</p> <p>1-72 Start Function [0] DC Hold/delay time * [2] Coast/delay time</p> <p>1-73 Flying Start * [0] Disabled [1] Enabled</p> <p>1-8* Stop Adjustments</p> <p>1-80 Function at Stop * [0] Coast [1] DC hold/MotorPreheat</p> <p>1-82 Min Speed for Function at Stop [Hz] 0.0 - 20.0 Hz, * 0.0</p> <p>1-9* Motor Temperature</p> <p>1-90 Motor Thermal Protection * [0] No protection [1] Thermistor warning [2] Thermistor trip [3] ETR warning 1 [4] ETR trip 1</p> <p>1-93 Thermistor Resource * [0] None [1] Analog input 53 [6] Digital input 29</p>	<p>2-** Brakes</p> <p>2-0* DC-Brake</p> <p>2-00 DC Hold/Motor Preheat Current 0 - 160%, * 50</p> <p>2-01 DC Brake Current 0 - 150%, * 50</p> <p>2-02 DC Braking Time 0.0 - 60.0 s, * 10.0</p> <p>2-04 DC Brake Cut In Speed 0.0 - 400.0 Hz, * 0.0</p> <p>2-1* Brake Energy Funct.</p> <p>2-17 Over-voltage Control [0] Disabled * [2] Enabled</p> <p>3-*** Reference / Ramps</p> <p>3-0* Reference Limits</p> <p>3-02 Minimum Reference (-4999.000) - 4999.000, * 0.000</p> <p>3-03 Maximum Reference (-4999.000) - 4999.000, * 50.000</p> <p>3-1* References</p> <p>3-10 Preset Reference -100.00 - 100.00 %, * 0.00</p> <p>3-11 Jog Speed [Hz] 0.0 - 400.0 Hz, * 5.0</p> <p>3-14 Preset Relative Reference -100.00 - 100.00, * 0.00</p> <p>3-15 Reference Resource 1 [0] No function * [1] Analog in 53 [2] Analog in 54 [11] Local bus reference</p> <p>3-16 Reference 2 Resource [0] No function [1] Analog in 53 * [2] Analog in 54 [11] Local bus reference</p> <p>3-17 Reference 3 Resource [0] No function [1] Analog in 53 [2] Analog in 54 * [11] Local bus reference</p> <p>3-4* Ramp 1</p> <p>3-41 Ramp 1 Ramp up Time 0.05 - 3600.00 s, *Size related</p> <p>3-42 Ramp 1 Ramp Down Time 0.05 - 3600.00 s, *Size related</p> <p>3-5* Ramp 2</p> <p>3-51 Ramp 2 Ramp up Time 0.05 - 3600.00 s, *Size related</p>	<p>3-52 Ramp 2 Ramp down Time 0.05 - 3600.00 s, *Size related</p> <p>3-8* Other Ramps</p> <p>3-80 Jog Ramp Time 0.05 - 3600.00 s, *Size related</p> <p>3-81 Quick Stop Ramp Time 0.05 - 3600.00 s, *Size related</p> <p>4-*** Limits / Warnings</p> <p>4-1* Motor Limits</p> <p>4-10 Motor Speed Direction [0] Clockwise * [2] Both directions</p> <p>4-12 Motor Speed Low Limit [Hz] 0.0 - 400 Hz, * 0.0 Hz</p> <p>4-14 Motor Speed High Limit [Hz] 0.1 - 400 Hz, * 65.0 Hz</p> <p>4-18 Current Limit 0 - 300%, * 110</p> <p>4-19 Max Output Frequency 0.0 - 400.0 Hz, * 65.0</p> <p>4-4* Adj. Warnings 2</p> <p>4-40 Warning Freq. Low 0.0-400.0 Hz, *400.0</p> <p>4-41 Warning Freq. High 0.0-400.0 Hz, *400.0</p> <p>4-5* Adj. Warnings</p> <p>4-50 Warning Current Low 0.00 - 194.00 A, * 0.00</p> <p>4-51 Warning Current High 0.00 - 194.00 A, * 194.00</p> <p>4-54 Warning Reference Low -4999.000 - 4999.000, * -4999.000</p> <p>4-55 Warning Reference High -4999.000 - 4999.000, * 4999.000</p> <p>4-56 Warning Feedback Low -4999.000 - 4999.000, * -4999.000</p> <p>4-57 Warning Feedback High -4999.000 - 4999.000, * 4999.000</p> <p>4-58 Missing Motor Phase Function [0] Off * [1] On</p> <p>4-6* Speed Bypass</p> <p>4-61 Bypass Speed From [Hz] 0.0 - 400.0, * 0.0</p> <p>4-63 Bypass Speed To [Hz] 0.0 - 400.0, * 0.0</p>	<p>4-64 Semi-Auto Bypass Set-up * [0] Off [1] Enable</p> <p>5-*** Digital In/Out</p> <p>5-0* Digital I/O mode</p> <p>5-00 Digital Input Mode * [0] PNP [1] NPN</p> <p>5-03 Digital Input 29 Mode * [0] PNP [1] NPN</p> <p>5-1* Digital Inputs</p> <p>5-10 Terminal 18 Digital Input [0] No operation [1] Reset [2] Coast inverse [3] Coast and reset inverse [4] Quick stop inverse [5] DC-brake inverse [6] Stop inverse [7] External Interlock * [8] Start [9] Latched start [10] Reversing [11] Start reversing [14] Jog [16] Preset ref bit 0 [17] Preset ref bit 1 [18] Preset ref bit 2 [19] Freeze reference [20] Freeze output [21] Speed up [22] Speed down [23] Set-up select bit 0 [34] Ramp bit 0 [37] Fire mode [52] Run permissive [53] Hand Start [54] Auto start [60] Counter A (up) [61] Counter A (down) [62] Reset Counter A [63] Counter B (up) [64] Counter B (down) [65] Reset Counter B [120] Lead Pump Start [121] Lead Pump Alternation [130] Pump 1 Interlock [131] Pump 2 Interlock [132] Pump 3 Interlock [133] Pump 4 Interlock [134] Pump 5 Interlock</p> <p>5-11 Terminal 19 Digital Input 请参阅参数 5-10, * [0] No operation</p>

表 1.5

参数概述			
5-12 Terminal 27 Digital Input 请参阅参数 5-10, *[2] Coast inverse 5-13 Terminal 29 Digital Input See par. 5-10, *[14 Jog] 5-3* Digital Outputs 5-34 On Delay, Digital Output 0.00 - 600.00 s, *0.01 s 5-35 Off Delay, Digital Output 0.00 - 600.00 s, *0.01 s 5-4* Relays 5-40 Function Relay *[0] No operation [1] Control ready [2] Drive ready [3] Drive ready/remote control [4] Enable / no warning [5] VLT running [6] Running / no warning [7] Run in range/no warning [8] Run on ref/no warning [9] 报警 [10] Alarm or warning [12] Out of current range [13] Below current, low [14] Above current, high [16] Below frequency, low [17] Above frequency, high [19] Below feedback, low [20] Above feedback, high [21] Thermal warning [22] Ready, no thermal warning [23] Remote, ready, no thermal warning [24] Ready, Voltage OK [25] Reverse [26] Bus OK [35] External Interlock [36] Control word bit 11 [37] Control word bit 12 [45] Bus Control [60] Comparator 0	[73] Logic rule 3 [74] Logic rule 4 [75] Logic rule 5 [80] SL digital output A [81] SL digital output B [82] SL digital output C [83] SL digital output D [160] No alarm [161] Running reverse [165] Local ref. active [166] Remote ref. active [167] Start command activ [168] Drive in hand mode [169] Drive in auto mode [193] Sleep Mode [194] Broken Belt Function [196] Fire Mode [198] Drive Bypass [211] Cascade Pump 1 [212] Cascade Pump 2 [213] Cascade Pump 3 [214] Cascade Pump 4 [215] Cascade Pump 5 5-41 On Delay, Relay 0.00 - 600.00 s, *0.01 s 5-42 Off Delay, Relay 0.00 - 600.00 s, *0.01 s 5-5* Pulse Input 5-9* Bus Controlled 5-90 Digital and Relay Bus Control 0 - 0xFFFFFFFF, * 0 6-** Analog In/Out 6-0* Analog I/O Mode 6-00 Live Zero Timeout Time 1 - 99s, * 10 6-01 Live Zero Timeout Function *[0] Off [1] Freeze output [2] Stop [3] Jogging [4] Max. speed [5] Stop and trip 6-1* Analog Input 53 6-10 Terminal 53 Low Voltage 0.00 - 10.00 V, * 0.07 6-11 Terminal 53 High Voltage 0.00 - 10.00 V, * 10.00 6-12 Terminal 53 Low Current 0.00 - 20.00, * 4.00 mA 6-13 Terminal 53 High Current 0.00 - 20.00, * 20.00 mA	6-14 Terminal 53 Low Ref./Feedb. Value -4999.000 - 4999.000, * 0.000 6-15 Terminal 53 High Ref./Feedb. Value -4999.000 - 4999.000, * 50.000 6-16 Terminal 53 Filter Time Constant 0.01 - 10.00 s, * 0.01 6-19 Terminal 53 mode [0] Current mode *[1] Voltage mode 6-2* Analog Input 54 6-20 Terminal 54 Low Voltage 0.00 - 10.00V, * 0.07 6-21 Terminal 54 High Voltage 0.00 - 10.00V, * 10.00 6-22 Terminal 54 Low Current 0.00 - 20.00, * 4.00mA 6-23 Terminal 54 High Current 0.00 - 20.00, * 20.00mA 6-24 Terminal 54 Low Ref./Feedb. Value -4999.000 - 4999.000, * 0.000 6-25 Terminal 54 High Ref./Feedb. Value -4999.000 - 4999.000, * 50.000 6-26 Terminal 54 Filter Time Constant 0.01 - 10.00, * 0.01 6-29 Terminal 54 mode [0] Current mode [0] Current mode *[1] Voltage mode 6-7* Analog Output 45 6-70 Terminal 45 Mode *[0] 0-20 mA [1] 4-20 mA [2] Digital Output 6-71 Terminal 45 Analog Output *[0] No operation [100] Output frequency [101] Reference [102] Feedback [103] Motor current [106] Power [139] Bus Control 6-72 Terminal 45 Digital Output *[0] No operation	[1] Control ready [2] Drive ready [3] Drive ready/remote control [4] Standby / no warning [5] Drive running [6] Running / no warning [7] Run in range/no warning [8] Run on ref/no warning [9] Alarm [10] Alarm or warning [12] Out of current range [13] Below current, low [14] Above current, high [21] Thermal warning [22] Ready, no thermal warning [23] Remote, ready, no thermal warning [24] Ready, Voltage OK [25] Reverse [26] Bus OK [35] External Interlock [45] Bus Control [60] Comparator 0 [61] Comparator 1 [62] Comparator 2 [63] Comparator 3 [64] Comparator 4 [65] Comparator 5 [70] Logic rule 0 [71] Logic rule 1 [72] Logic rule 2 [73] Logic rule 3 [74] Logic rule 4 [75] Logic rule 5 [80] SL digital output A [81] SL digital output B [82] SL digital output C [83] SL digital output D [160] No alarm [161] Running reverse [165] Local ref. active [166] Remote ref. active [167] Start command activ [168] Drive in hand mode [169] Drive in auto mode [193] Sleep Mode [194] Broken Belt Function [196] Fire Mode [198] Bypass Mode [200] Full capacity [201] Pump 1 running [202] Pump 2 running [203] Pump 3 running [204] Pump 4 running [205] Pump 5 running

表 1.6

参数概述			
[211] Cascade Pump 1 [212] Cascade Pump 2 [213] Cascade Pump 3 [214] Cascade Pump 4 [215] Cascade Pump 5 6-73 Terminal 45 Output Min Scale 0.00 - 200.00%, * 0.00 6-74 Terminal 45 Output Max Scale 0.00 - 200.00%, * 100.00 6-76 Terminal 45 Output Bus Control 0.00 - 100.00%, * 0.00 6-9* Analog Output 42 6-90 Terminal 42 Mode * [0] 0-20 mA [1] 4-20 mA [2] Digital Output 6-91 Terminal 42 Analog Output * [0] No operation [100] Output frequency [101] Reference [102] Feedback [103] Motor current [105] TorquereltoRated [106] Power [139] Bus Control 6-92 Terminal 42 Digital Output * [0] No operation [1] Control ready [2] Drive ready [3] Drive ready/remote control [4] Enable / no warning [5] Drive running [6] Running / no warning [7] Run in range/no warning [8] Run on ref/no warning [9] Alarm [10] Alarm or warning [12] Out of current range [13] Below current, low [14] Above current, high [21] Thermal warning [22] Ready, no thermal warning [23] Remote, ready, no thermal warning [24] Ready, Voltage OK [25] Reverse [26] Bus OK [35] External Interlock [45] Bus Control [60] Comparator 0	[61] Comparator 1 [62] Comparator 2 [63] Comparator 3 [64] Comparator 4 [65] Comparator 5 [70] Logic rule 0 [71] Logic rule 1 [72] Logic rule 2 [73] Logic rule 3 [74] Logic rule 4 [75] Logic rule 5 [80] SL digital output A [81] SL digital output B [82] SL digital output C [83] SL digital output D [160] No alarm [161] Running reverse [165] Local ref. active [166] Remote ref. active [167] Start command activ [168] Drive in hand mode [169] Drive in auto mode [193] Sleep Mode [194] Broken Belt Function [196] Fire Mode [198] Drive Bypass [200] Full capacity [201] Pump 1 running [202] Pump 2 running [203] Pump 3 running [204] Pump 4 running [205] Pump 5 running [211] Cascade Pump 1 [212] Cascade Pump 2 [213] Cascade Pump 3 [214] Cascade Pump 4 [215] Cascade Pump 5 6-93 Terminal 42 Output Min Scale 0.00 - 200.00%, * 0.00 6-94 Terminal 42 Output Max Scale 0.00 - 200.00%, * 100.00 6-96 Terminal 42 Output Bus Control 0.00 - 100.00%, * 0.00 8-** Comm. and Options 8-0* Comm. General Settings 8-01 Control Site * [0] Digital and ctrl.word [1] Digital only [2] Controlword only 8-02 Control Source [0] None * [1] FC Port 8-03 Control Timeout Time 0.1 - 6500.0s, * 1.0	8-04 Control Timeout Function * [0] Off [1] Freeze output [2] Stop [3] Jogging [4] Max. speed [5] Stop and trip [20] N2 Override Release 8-06 Reset Control Word Timeout * [0] No function [1] Do reset 8-3* FC Port Settings 8-30 Protocol * [0] FC [2] Modbus RTU [3] Metasys N2 [4] FLN [5] BACnet 8-31 Address 1 - 247, * 1 8-32 FC Port Baud Rate [0] 2400 Baud [1] 4800 Baud * [2] 9600 Baud [3] 19200 Baud [4] 38400 Baud [5] 57600 Baud [6] 76800 Baud [7] 115200 Baud 8-33 FC Port Parity * [0] Even Parity, 1 Stop Bit [1] Odd Parity, 1 Stop Bit [2] No Parity, 1 Stop Bit [3] No Parity, 2 Stop Bits 8-35 Minimum Response Delay 0.001 - 0.500s, * 0.010 8-36 Max Response Delay 0.100 - 10.000s, * 5.000 8-37 Max Inter-char delay 0.025 - 0.025s, * 0.025 8-5* Digital/Bus 8-50 Coasting Select [0] Digital input [1] Bus [2] Logic AND * [3] Logic OR 8-51 Quick Stop Select [0] Digital input [1] Bus [2] Logic AND * [3] Logic OR	8-52 DC Brake Select [0] Digital input [1] Bus [2] Logic AND * [3] Logic OR 8-53 Start Select [0] Digital input [1] Bus [2] Logic AND * [3] Logic OR 8-54 Reversing Select [0] Digital input [1] Bus [2] Logic AND * [3] Logic OR 8-55 Set-up Select [0] Digital input [1] Bus [2] Logic AND * [3] Logic OR 8-56 Preset Reference Select [0] Digital input [1] Bus [2] Logic AND * [3] Logic OR 8-7* Bacnet 8-70 BACnet Device Instance 0 - 0x400000UL * 1 8-72 MS/TP Maxmaster 0 - 127, * 127 8-73 MS/TP Max Info Frames 1 - 65534, * 1 8-74 "I am" Service * [0] Send at power-up [1] Continuously 14-5* Environment 14-50 RFI Filter [0] Off * [1] On 14-51 DC-link Voltage Compensation [0] Off * [1] On 14-52 Fan Control * [0] Auto [4] Auto Low temp env 14-53 Fan Monitor [0] Disabled * [1] Warning [2] Trip 14-55 Output Filter * [0] No Filter [1] Sine-Wave Filter [3] Sine-Wave Filter with Feedback 8-75 Intialisation Password

表 1.7

参数概述			
8-8* FC Port Diagnostics 8-80 Bus Message Count 0 - 65536, * 0 8-81 Bus Error Count 0 - 65536, * 0 8-82 Slave Message Rcvd 0 - 65536, * 0 8-83 Slave Error Count 0 - 65536, * 0 8-84 Slave Message Sent 0 - 65536, * 0 8-85 Slave Timeout Errors 0 - 65536, * 0 8-88 Reset FC port Diagnostics * [0] Do not reset [1] Reset counter 8-9* Bus Feedback 8-94 Bus feedback 1 -32768 - 32767, * 0 13-** Smart Logic 13-0* SLC Settings 13-00 SL Controller Mode * [0] Off [1] On 13-01 Start Event [0] False [1] True [2] Running [3] In range [4] On reference [7] Out of current range [8] Below I_{low} [9] Above I_{high} [16] Thermal warning [17] Mains out of range [18] Reversing [19] Warning [20] Alarm (trip) [21] Alarm (trip lock) [22] Comparator 0 [23] Comparator 1 [24] Comparator 2 [25] Comparator 3 [26] Logic rule 0 [27] Logic rule 1 [28] Logic rule 2 [29] Logic rule 3 [33] Digital input 18 [34] Digital input 19 [35] Digital input 27 [36] Digital input 29 * [39] Start command [40] Drive stopped [41] Reset trip [42] Auto reset trip	[43] Key Ok [44] Key Reset [47] Key Up [48] Key Down [50] Comparator 4 [51] Comparator 5 [60] Logic rule 4 [83] Broken belt 13-02 Stop Event See par. 13-02, * [40] Drive stopped 13-03 Reset SLC * [0] Do not reset [1] Reset SLC 13-1* Comparators 13-10 Comparator Operand * [0] Disabled [1] Reference [2] Feedback [3] Motor speed [4] Motor current [6] Motor power [7] Motor voltage [8] DC-link voltage [12] Analog in 53 [13] Analog in 54 [20] Alarm number [30] Counter A [31] Counter B 13-11 Comparator Operator [0] Less Than * [1] Approx. Equal [2] GreaterThan 13-12 Comparator Value -9999.0 - 9999.0, * 0.0 13-2* Timers 13-20 SL Controller Timer 0.00 - 3600.00, * 0.00 13-4* Logic Rules 13-40 Logic Rule Boolean 1 See par. 13-01, * [0] False 13-41 Logic Rule Operator 1 * [0] Disabled [1] AND [2] OR [3] AND NOT [4] OR NOT [5] NOT AND [6] NOT OR [7] NOT AND NOT [8] NOT OR NOT 13-42 Logic Rule Boolean 2 请参阅参数 13-01, * [0] False 13-43 Logic Rule Operator 2 请参阅参数 13-41, * [0] Disabled	13-44 Logic Rule Boolean 3 请参阅参数 13-01, * [0] False 13-5* States 13-51 SL Controller Event See par. 13-01, * [0] False 13-52 SL Controller Action * [0] Disabled [1] No action [2] Select set-up 1 [3] Select set-up 2 [10] Select preset ref 0 [11] Select preset ref 1 [12] Select preset ref 2 [13] Select preset ref 3 [14] Select preset ref 4 [15] Select preset ref 5 [16] Select preset ref 6 [17] Select preset ref 7 [18] Select ramp 1 [19] Select ramp 2 [22] Run [23] Run reverse [24] Stop [25] Qstop [26] DC Brake [27] Coast [28] Freeze output [29] Start timer 0 [30] Start timer 1 [31] Start timer 2 [32] Set digital out A low [33] Set digital out B low [34] Set digital out C low [35] Set digital out D low [38] Set digital out A high [39] Set digital out B high [40] Set digital out C high [41] Set digital out D high [60] Reset Counter A [61] Reset Counter B [70] Start timer 3 [71] Start timer 4 [72] Start timer 5 [73] Start timer 6 [74] Start timer 7 [100] Reset Alarm 14-** Special Functions 14-0* Inverter Switching 14-01 Switching Frequency [0] Ran3 [1] Ran5 [2] 2.0 kHz [3] 3.0 kHz [4] 4.0 kHz [5] 5.0 kHz [6] 6.0 kHz [7] 8.0 kHz	[8] 10.0 kHz [9] 12.0kHz [10] 16.0kHz 14-03 Overmodulation [0] Off * [1] On 14-08 Damping Gain Factor 0 - 100-%, * 96 14-1* Mains on/off 14-12 Function at Mains Imbalance * [0] Trip [1] Warning [2] Disabled [3] Derate 14-2* Reset Functions 14-20 Reset Mode * [0] Manual reset [1] Automatic reset x 1 [2] Automatic reset x 2 [3] Automatic reset x 3 [4] Automatic reset x 4 [5] Automatic reset x 5 [6] Automatic reset x 6 [7] Automatic reset x 7 [8] Automatic reset x 8 [9] Automatic reset x 9 [10] Automatic reset x 10 [11] Automatic reset x 15 [12] Automatic reset x 20 [13] Infinite auto reset 14-21 Automatic Restart Time 0 - 600s, * 10 14-22 Operation Mode * [0] Normal operation [2] Initialisation 14-27 Action At Inverter Fault [0] Off * [1] On 14-28 Production Settings * [0] No action [1] Service reset [3] Software Reset 14-29 Service Code 0 - 0x7FFFFFFF, * 0 14-3* Current Limit Ctrl. 14-4* Energy Optimising 14-40 VT Level 40 - 90%, * 90% 14-41 AEO Minimum Magnetisation 40 - 75%, * 66 14-63 Min Switch Frequency 1 - 16kHz, * 1

表 1.8

参数概述			
15-** Drive Information 15-0* Operating Data 15-00 Operating Hours 0 - 2147483647, * 0 15-01 Running Hours 0 - 2147483647, * 0 15-02 kWh Counter 0 - 65535, * 0 15-03 Power Up's 0 - 2147483647, * 0 15-04 Over Temp's 0 - 65535, * 0 15-05 Over Volt's 0 - 65535, * 0 15-06 Reset kWh Counter * [0] Do not reset [1] Reset counter 15-07 Reset Running Hours Counter * [0] Do not reset [1] Reset counter 15-3* Fault Log 15-30 Fault Log: Error Code 0 - 255, * 0 15-4* Drive Identification 15-40 FC Type 15-41 Power Section 15-42 Voltage 15-43 Software Version 15-44 OrderedTypeCode 15-46 变频器 Ordering No 15-47 Power Card Ordering No 15-48 LCP Id No 15-49 Software ID Control Card 15-50 Software ID Power Card 15-51 变频器 Serial Number 15-53 Power Card Serial Number 16-** Data Readouts 16-0* General Status 16-00 Control Word 0 - 65535, * 0 16-01 Reference [Unit] -4999.000 - 4999.000, * 0.000 16-02 Reference % -200.0 - 200.0, * 0.0 16-03 Status Word 0 - 65535, * 0	16-05 Main Actual Value [%] -200.00 - 200.00, * 0.00 16-09 Custom Readout 0.00 - 9999.00, * 0.00 16-1* Motor Status 16-10 Power [kW] 0.000-4.294, 967.500, *0.000 16-11 Power [hp] 0.000 - 2.294, 967.500 *0.000 16-3* Drive Status 16-30 DC Link Voltage 0 - 65535, * 0 16-34 Heatsink Temp. 0 - 255, * 0 16-35 Inverter Thermal 0 - 255%, * 0 16-36 Inv. Nom. Current 0.00 - 655.35, * 0.00 16-37 Inv. Max. Current 0.00 - 655.35 16-38 SL Controller State 0 - 255, * 0 16-5* Ref. and Feedb. 16-50 External Reference -200.0 - 200.0%, * 0.0 16-52 Feedback -4999.000 - 4999.000, * 0.000 16-6* Inputs and Outputs 16-60 Digital input 0 - 65535, * 0 16-61 Terminal 53 Setting * [0] Current mode [1] Voltage mode 16-62 Analog Input 53 0.00 - 10.00, * 1.00 16-63 Terminal 54 Setting * [0] Current mode [1] Voltage mode 16-64 Analog Input 54 0.00 - 20.00, * 1.00 16-65 Analog Output 42 [mA] 0.00 - 20.00, * 0.00 16-61 Digital Output 16-72 Counter A -32768 - 32767, * 0 16-73 Counter B -32768 - 32767, * 0 16-79 Analog output 45 20 - 20mA, * 0 16-8* Fieldbus / FC Port 16-86 FC Port REF 1 -32768 - 32767, * 0	16-9* Diagnosis Readouts 16-90 Alarm Word 0 - 0xFFFFFFFFUL, * 0 16-91 Alarm Word 2 0 - 0xFFFFFFFFUL, * 0 16-92 Warning Word 0 - 0x7FFFFFFFUL, * 0 16-93 Warning Word 2 0 - 0x7FFFFFFFUL, * 0 16-94 Ext. Status Word 0 - 0x7FFFFFFFUL, * 0 16-95 Ext. Status Word 2 0 - 0x7FFFFFFFUL, * 0 18-**Extended Motor Data 18-1* Firemode Log 18-10 Firemode log: Event 0-255, *0 20-** FC Closed Loop 20-0* Feedback 20-00 Feedback 1 Source * [0] No function [1] Analog in 53 [2] Analog in 54 [100] Bus Feedback 1 20-01 Feedback 1 Conversion * [0] Linear [1] Square root 20-8* PI Basic Setting 20-81 Process PI Normal/ Inverse Control * [0] Normal [1] Inverse 20-83 Process PI Start Speed[Hz] 0.0 - 200.0, * 0.0 20-84 On Reference Bandwidth 0 - 200%, * 5 20-9* PI Controller 20-91 PI Anti Windup [0] Off * [1] On 20-93 PI Proportional Gain 0.00 - 10.00, * 0.01 20-94 PI Integral Time 0.10 - 9999.00s, * 9999.00 20-97 Process PI Feed Forward Factor 0 - 400%, * 0	22-** Appl. functions 22-4* Sleep mode 22-40 Minimum Run Time 0 - 600 s, * 10 22-41 Minimum Sleep Time 0 - 600 s, * 10 22-43 Wake-Up Speed [Hz] 0.0 - 400.0, * 100.0 22-44 Wake-Up Ref./FB difference 0 - 100%, * 10 22-45 Setpoint Boost -100 - 100%, * 0 22-46 Maximum Boost Time 0 - 600 s, * 60 22-47 Sleep Speed [Hz] 0.0 - 400.0, * 0.0 22-6* Broken Belt Detection 22-60 Broken Belt Detection * [0] Off [1] Warning [2] Trip 22-61 Broken Belt Torque 5 - 100%, * 10 22-62 Broken Belt Delay 0 - 600 s, * 10 24-** Appl. functions 2 24-0* Fire mode 24-00 Fire Mode Function * [0] Disabled [1] Enabled Run Forward [2] Enabled Run Reverse [3] Enable-Coast [4] Enabled - Run Fwd/Rev 24-05 Fire Mode Preset Reference -100 - 100%, * 0 24-09 Fire Mode Alarm Handling * [1] Trip, Critical Alarms [2] Trip, All Alarms/Test 24-1* Drive Bypass 24-10 Drive Bypass Function * [0] Disabled [2] Enabled (Fire Mode only) 24-11 Bypass Delay Timer 0 - 600 s, * 0

表 1.9



www.danfoss.com/drives

Danfoss 对其目录、手册以及其它印刷资料可能出现的错误不负任何责任。Danfoss 保留未预先通知而更改产品的权利。该限制并适用于已订购但更改并不会过多改变已同意规格的货物。
本材料所引用的商标均为相应公司之财产。Danfoss 及 Danfoss 的标记均为 Danfoss A/S 之注册商标。版权所有。

丹佛斯（天津）有限公司

地址：天津武清开发区 3 号路
电话：022 8212 6400
传真：022 8212 6407
邮编：301700
Email: danfoss@public.tpt.tj.cn

丹佛斯有限公司（香港）

香港德辅道西 410-418
太平洋广场 1506-1507 室
+ 852 2517 3872
+ 852 2517 3908
swhk@danfoss.com.hk

丹佛斯（天津）有限公司

北京分公司
北京市北辰东路 8 号
汇宾大厦 B0720
010 6492 3762 6492 6445
010 6492 6432
100101
danfoss@public-east-cn-net

丹佛斯有限公司

上海代表处
上海市漕宝路 509 号
新漕河泾大厦 1904-06 室
021 6485 1972
021 6485 1977
200233
danfoss@gate.uninet.co.cn

