

ICS469-40 and ICS469-100

Flexible Global Weighing System



Extremely Flexible

Customer specific configuration including height, width, length, location of the weighing terminal and construction materials. The ICS469 series fulfils the greatest multitude of system integration and production line requirements to set new standards in integration versatility.



Multilingual Operation

The ICS469 terminal has been designed with the operator in mind. It is pre-configured with nine different languages to support global business relations, reduce operator errors and ease integration, service and training requirements.



Global Service Support

An extensive global service network fully supports cross-border contracts and ensures not only timely support but also the availability and quick delivery of spare parts to reduce downtime and keep process running smoothly.



Weights and Measures Certified

This optional checkweigher version meets all prerequisites for an EC conformity assessment procedure and an official verification in all other countries in the world.



Universal Weighing Solution

Future Orientated and Very Flexible

The ICS469-40 and ICS469-100 have been designed to fulfil the most demanding system integration requirements. These extremely flexible weighing solutions represent the best possible performance in the widest range of applications currently available on the market.

You and your business will positively benefit from the following key points:

- Extremely flexible construction
- Easy to use multilingual operating terminal
- Global service and spare parts support
- Local Weights and Measures certification
- Large range of weighing connectivity options
- T&L specific characteristics as standard

Technical data

ICS469-40 and ICS469-100

– Fulfil your integration requirements

The ICS469 weighing systems offer a wide range of standard features and options to further ease integration and configure the best possible solution for your weighing application requirements especially in T&L applications.

The high quality construction materials and precision engineering are a hallmark of all METTLER TOLEDO weighing systems and ensure the reliability and accuracy you require to get the best possible performance from your application.

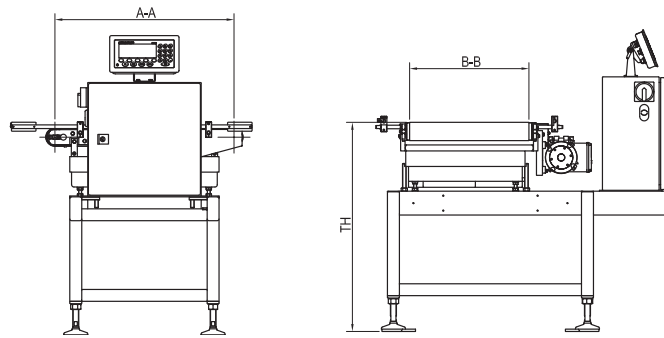

Typical dimensions in mm (ICS469-40 with A-A 600 mm)

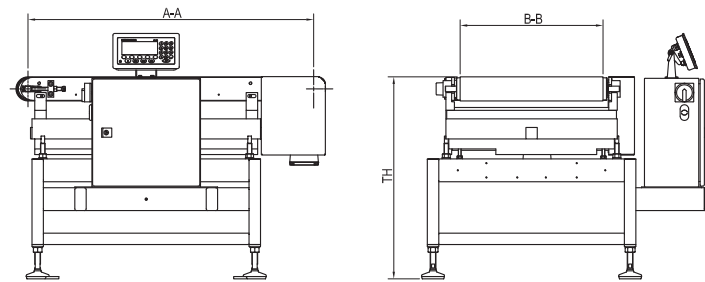

Typical dimensions in mm (ICS469-100 with A-A 1000 mm)

Characteristics

- "Weights and Measures" design-approved
- Classification of weights in three weight zones
- Manual or automatic re-zero
- Reject control signal for reject devices
- Contact for over max. weight and under min. weight
- Standard surface finish: painted (powder coated)
- 230 V (AC), single-phase, 50/60 Hz, N, PE, ≥ 750 VA (ICS469-40), ≥ 1200 VA (ICS469-100)

Weighing terminal

- Housing: stainless steel, IP68/IP69k
- Clear weight display of current weight
- Imperial weight display for use e.g. in North America
- Tare weight functionality
- Soft-touch industrial quality membrane keypad
- Operator-friendly with numerical input buttons
- 25 product memories
- High visibility colour coded display of weight classification
- Special dynamic weighing menu to ease configuration
- Multilingual display with 9 standard languages
- Display of current Weights and Measures data
- Automatic detection of replacement weighcells
- Data communication interface: RS232C

Options and accessories

- Sorting/rejecting devices
- Infeed conveyors, outfeed conveyors
- Guide rails
- Special voltages on request
- Interfaces: RS422, Ethernet, Fieldbus (Profibus DP, Ethernet/IP)
- Emergency stop
- Stainless steel (V2A) construction
- Increased water ingress protection IP65 or IP65 V2A
- UL 508a certification

Technical details	ICS469-40	ICS469-100
Weighing range *	0 g to 40 kg	0 g to 120 kg
Accuracy**	from ± 5 g at 3 Sigma	from ± 20 g at 3 Sigma
Throughput (weighings/minute)	up to 100	up to 80
Distance between roller centres (A-A)	600, 800, 1000 mm	1000, 1200, 1500, 1700 mm
Belt width (B-B)	300, 400, 500 mm	500, 600, 800, 900 mm
Line height (TH) (± 50 mm)	500 - 1000 mm	500 - 1000 mm

* depending on type of weighing conveyor used

** depending on weight, dimensions and transport behaviour of the product weighed



Mettler-Toledo Garvens GmbH

Kampstrasse 7
31180 Giesen, Germany
Telephone +49 (0) 5121 933-0
Facsimile +49 (0) 5121 933-456
e-mail garvens@mt.com

Subject to technical modifications
© Mettler-Toledo Garvens GmbH
Printed in Germany 0712/174 UK

www.mt.com/garvens

For more information