

No. 4 Single Edge Track Systems 单边沿导轨系统

Track system single edge slides and segments can be used to construct a single edge track system which provides a wide platform the rigid support of large components. The large rear face of the single edge slide enables a full width rack to be accommodate providing for a strong drive. This can be used for the construction of a gear driven duplex track system.

This data sheet is intended as a guide to single edge track systems but it is recommended to discuss your application with Hepco's Technical Department in the first instance.

Single edge track system

Track system single edge curved segments

单边缘的弧线导轨系统

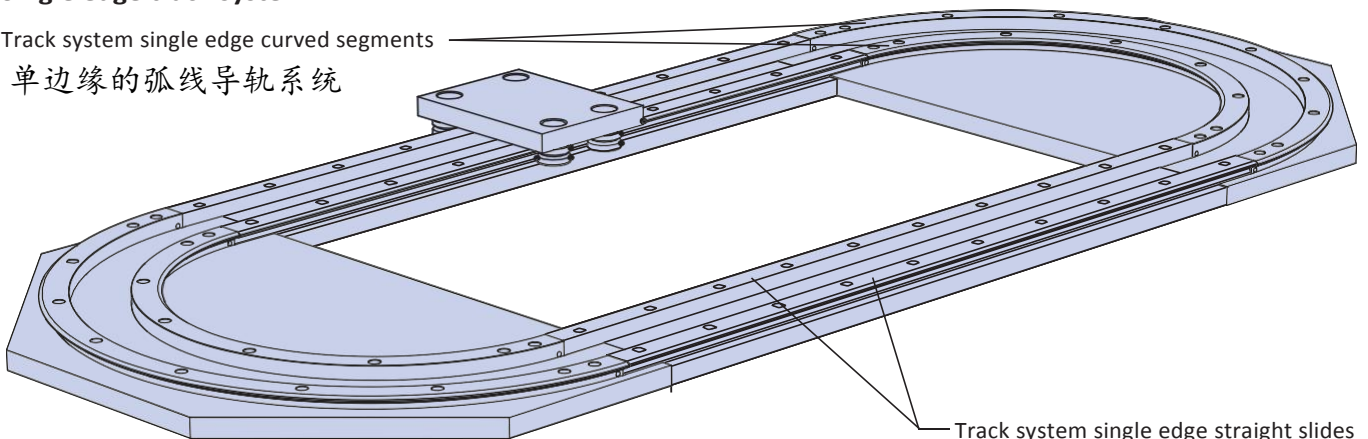

Track system single edge straight slides

单边沿直线导轨系统

Gear driven single edge slide track system

齿轮驱动的单边沿导轨运行系统

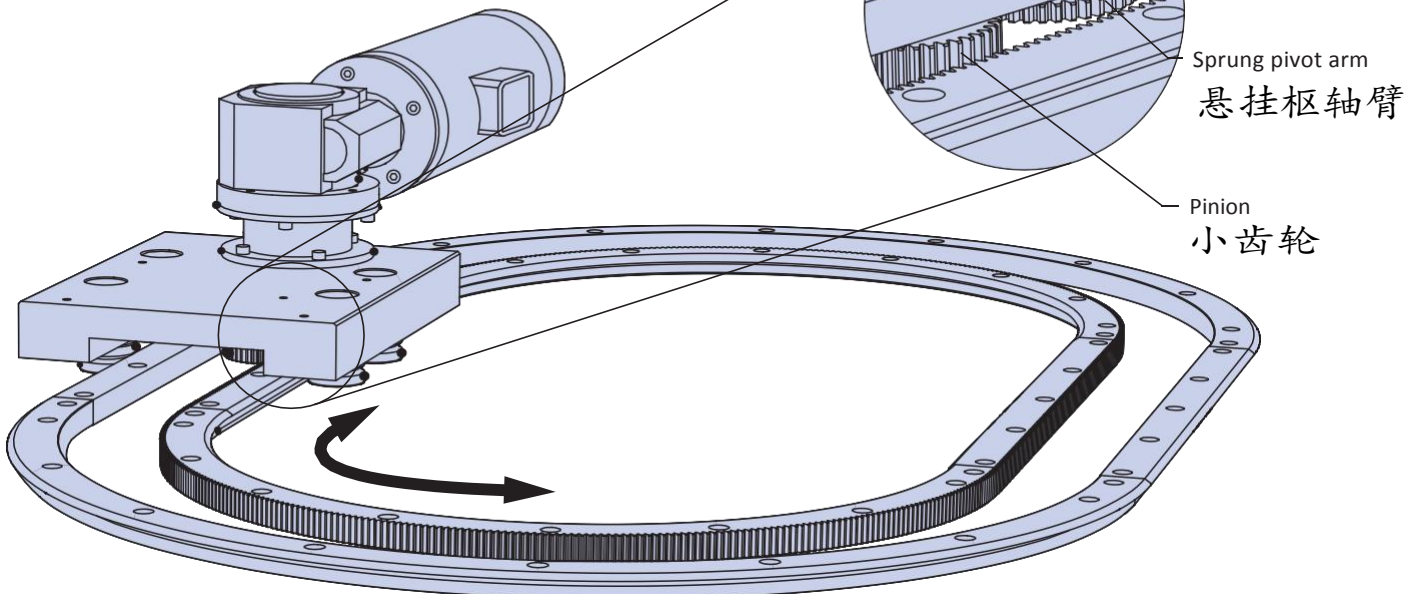

Sprung pivot arm

悬挂枢轴臂

Pinion

小齿轮

Single edge track system with a gear drive on the inner curved and straight slides, engages with a pinion driven from the motor. A sprung pivot arm ensures that the pinion remains engaged with the rack as it travels from straight to curve.

单边沿导轨系统与内部圆弧导轨和直线齿轮传动导轨系统，

啮合的小齿轮从所述马达驱动。

由悬挂枢轴臂确保啮合齿轮齿条是在它的内侧行进直曲线运行。

No. 4 Single Edge Track Systems 单边沿导轨系统

Single edge track systems are designed to suit individual requirements. They are made up of track system single edge straight slides and track system single edge curved segments. More details of these components can be found on pages 45-46 of the main PRT2 catalogue. It is recommended that they are supplied with a base plate to ensuring correct alignment of the slide to the ring segments, the examples below are shown with base plates, these can be supplied by Hepco, please discuss at the time of ordering.

Single edge track systems can also be rack driven as shown in the example on page 1 and can be oval or rectangular in shape as shown below. The carriage plate will be designed to suit this requirement. Once the design has been decided a drawing will be produced for customer approval before the order is placed.

Oval System

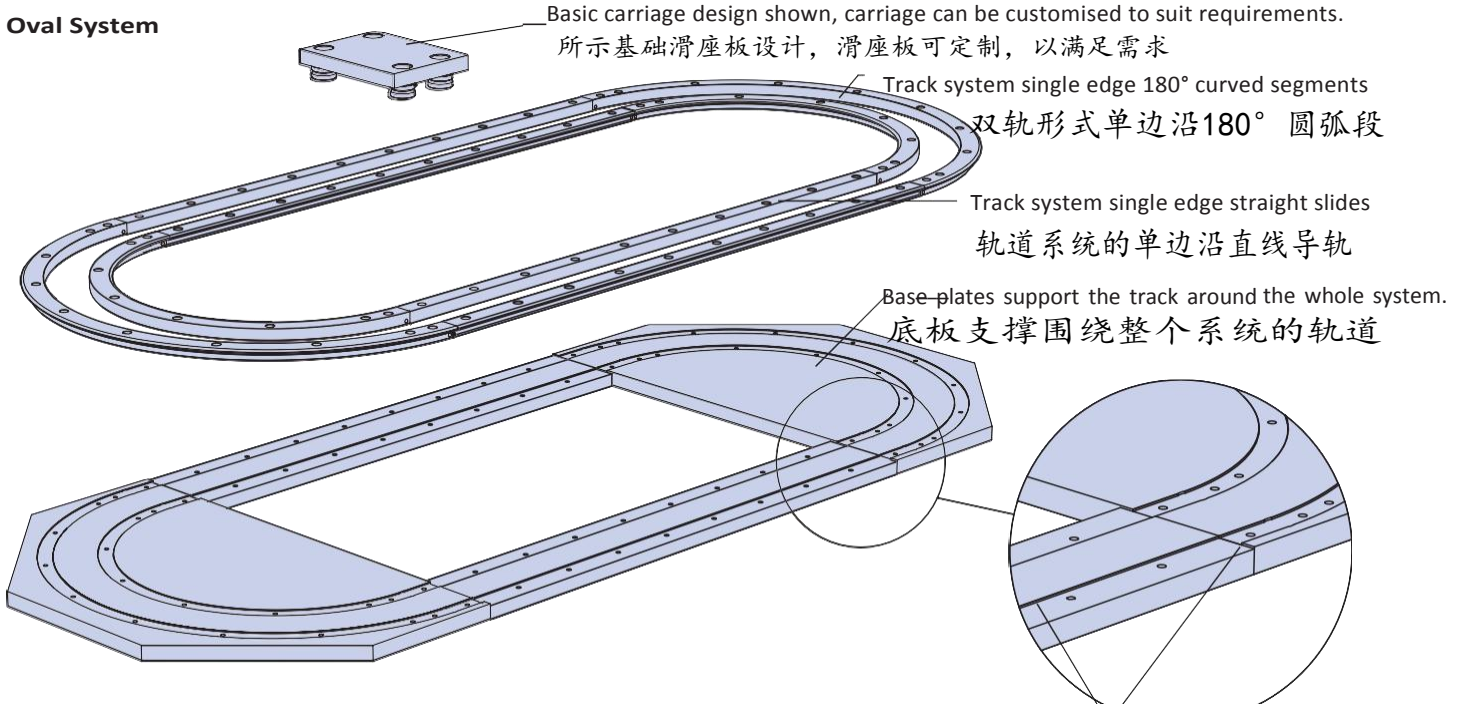

Registers machined into the base plate to ensure accurate location of single edge slides and rings.

加工成底板的对齐块, 以确保单边沿轨道和圆弧导轨的准确位置

矩形系统

Rectangular System

Track system single edge straight slides

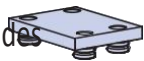

轨道系统的单边沿直线导轨

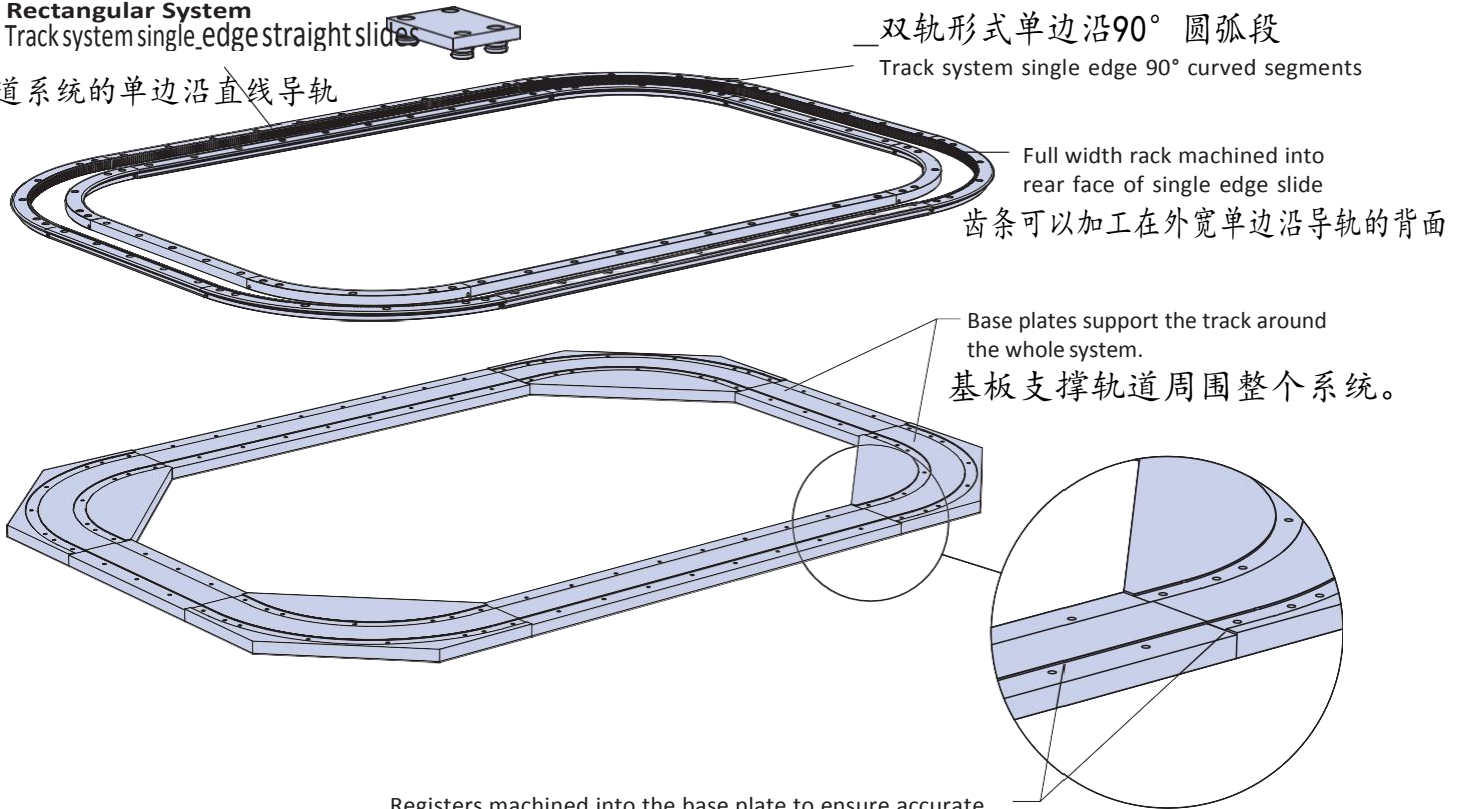

Registers machined into the base plate to ensure accurate location of single edge slides and rings.

加工成底板的对齐块, 以确保单边沿轨道和圆弧导轨的准确位置

No. 4 Single Edge Track Systems 单边沿导轨系统

Below are shown the two standard track configurations available, oval and rectangular, and the relevant dimensions to help with selection. There are two sizes of each configuration available, a **small** version which uses TNSE track system slides combined with TRIS 278 & TRES 376 segments and a **large** size which uses TNME single edge slides combined with TRIM 482 & TREM 655 segments.

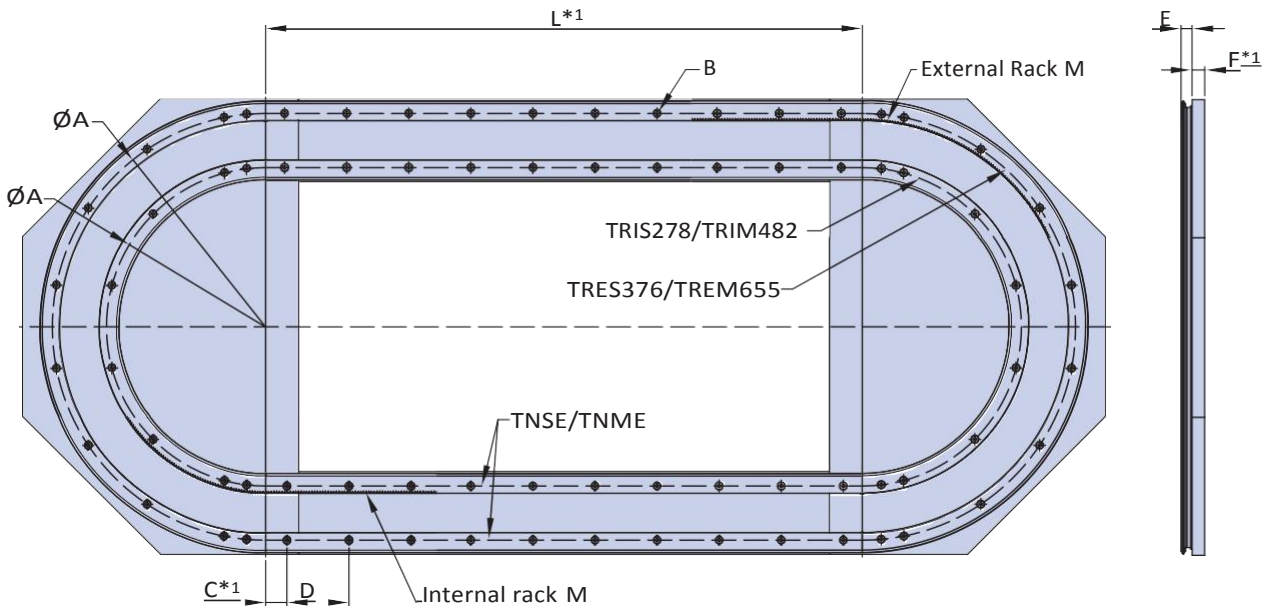

Ring Size	For use with slide size	For use with bearing size	A	B	C	D	E	F	M (module)
TRIS 278	TNSE	...J25...	261	M5	30	90	12.25	18	1
TRES 376	TNSE	...J25...	351	M5	30	90	12.25	18	1
TRIM 482	TNME	...J34...	461.5	M6	30	90	15.5	18	1.25
TREM 655	TNME	...J34...	618.5	M6	30	90	15.5	18	1.25

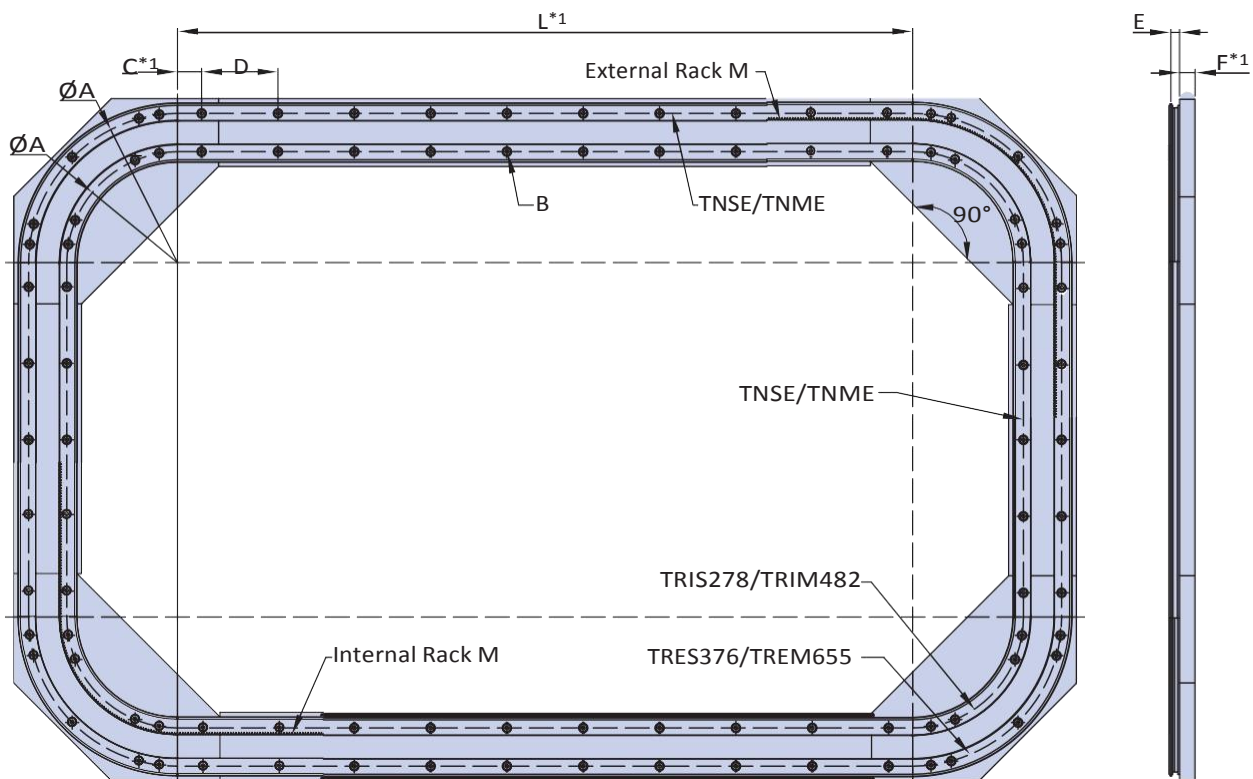

Ring Size	For use with slide size	For use with bearing size	A	B	C	D	E	F	M (module)
TRIS 278	TNSE	...J25...	261	M5	30	90	12.25	18	1
TRES 376	TNSE	...J25...	351	M5	30	90	12.25	18	1
TRIM 482	TNME	...J34...	461.5	M6	30	90	15.5	18	1.25
TREM 655	TNME	...J34...	618.5	M6	30	90	15.5	18	1.25

*1 Dimensions L and C and F can be customised to suit the requirement, please specify when ordering a single edge track system

No. 4 Single Edge Track Systems 单边沿导轨系统

The carriage plates shown in the data sheet are of a relatively simple design, carriage plates can be customised to suit individual requirements and can be designed to accommodate motors and pinions if a drive is required, please discuss with Hepco's technical department when ordering the track system. The image below shows how the basic carriage will be constructed with the two eccentric bearings on the outer edge of the carriage plate and thus the outer edge of the track system and the concentric bearings on the inner edge.

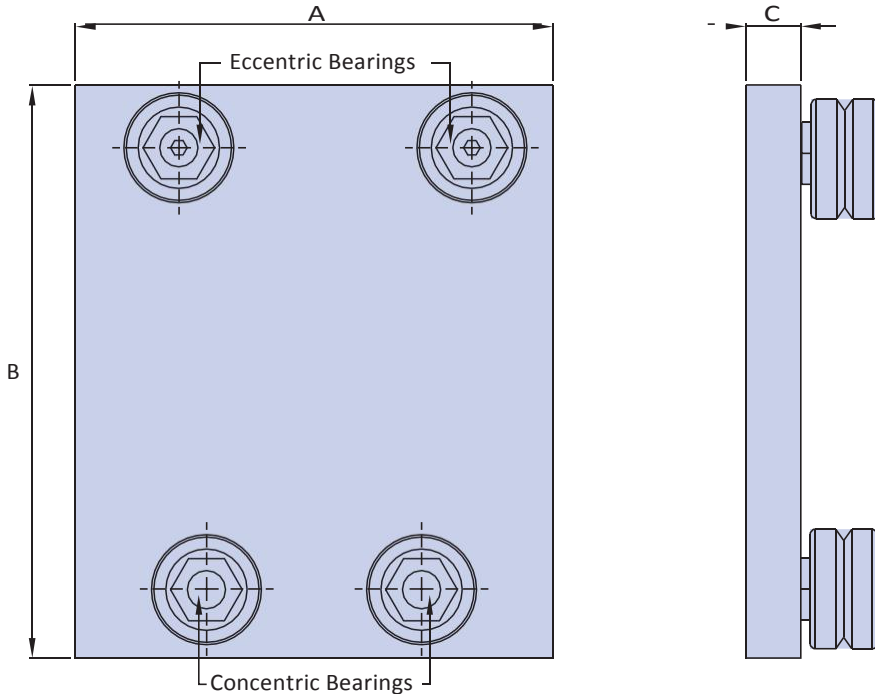
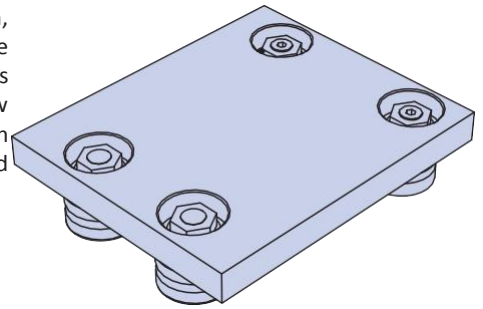

1. Dimensions A, B and C can be customised to suit application, special designs can also be accommodated, please contact Hepco's technical department for more information.
2. For more information on bearing sizes, please see pages 34-35 main PRT2 catalogue.

Ordering Information 订购信息

It is recommended to discuss your application with Hepco's technical department so a tailored solution can be provided to suit your needs. Listed below is some information that would need to be provided and will assist communication when specifying and ordering the track system, it may also be useful to supply a sketch or drawing to aid discussion.

Specify the track shape - Oval
指定轨道的形状 椭圆形

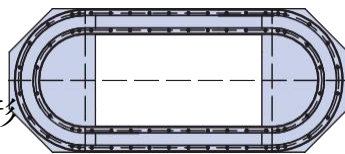

Rectangle
矩形

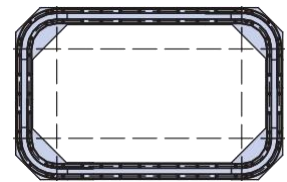

Specify the track size and length - Small (uses TNSE slides), Large (uses TNME slides), see page 3 for more details. Specify dimensions L, C & F, see page 3 for more details.

Specify track additional features - Specify whether a rack is required or any other additional features.

Specify the back plate - Decide whether Hepco to supply the back plate with the track system or to be supplied by the customer.

Specify the carriage - Specify dimensions A, B & C as shown above. If any additional features, i.e. pinions or motors to be fitted, or special design is required please supply a drawing.

Hepco总代理: 广州权硕机电设备有限公司
联系: 何工 13728889034 QQ225038320
新浪博客: <http://blog.sina.com.cn/heguodong0615>
视频案例: <http://i.youku.com/heguodong2012>

